

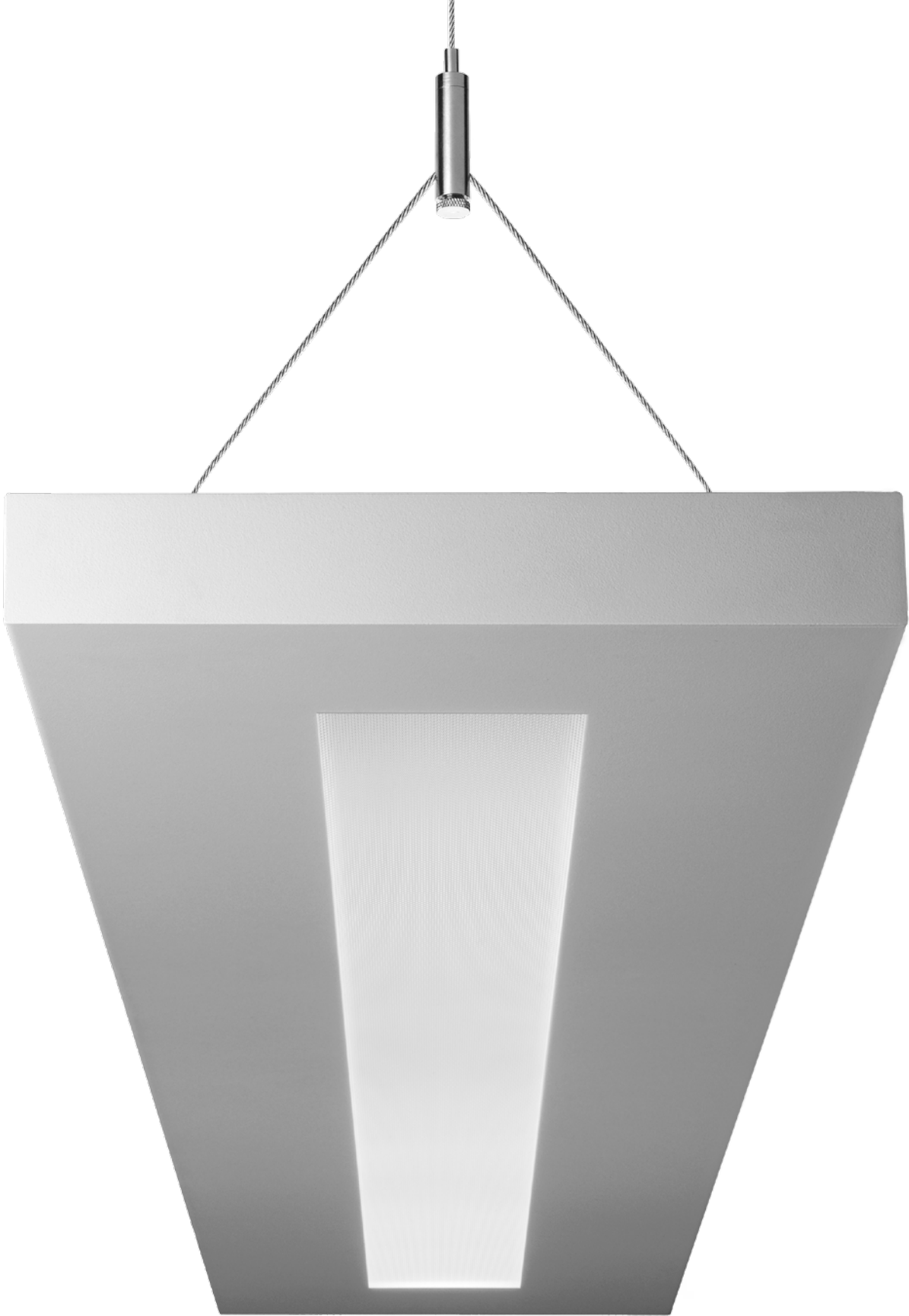

CROWN:  
- use compass  
- use center punch & pin or chalk



# TWELVE LED

With sleek style and timeless appeal, Twelve™ LED illuminates any environment. We've matched the diffuse and comfortable direct/indirect distribution of our fluorescent design, enabling a wide variety of mounting heights and spacings to suit every application. Discerning designer-friendly details like Gradient Optic™ and MicroGlow™ lens are only available from Focal Point. L90 at 100,000 hours and up to 35% energy savings over fluorescent makes Twelve LED a smart and easy choice.

## FEATURES

- 75% indirect / 25% direct illumination
- Acrylic or MicroGlow diffuser
- 5 Standard output levels
- 3000K, 3500K, 4000K
- CRI >80
- 0-10V dimming in 10% and 1% ranges
- Lutron EcoSystem dimming
- Up to **108 LPW**
- L90 at 100,000 hours
- 5 year limited warranty
- Wall mount companion



Visit [designlights.org/QPL](http://designlights.org/QPL) for model specifics

Acrylic

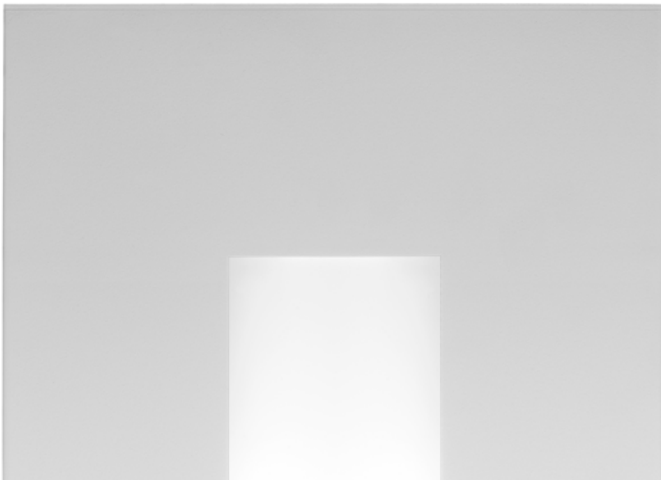

MicroGlow  
Low-brightness, increased visual comfort



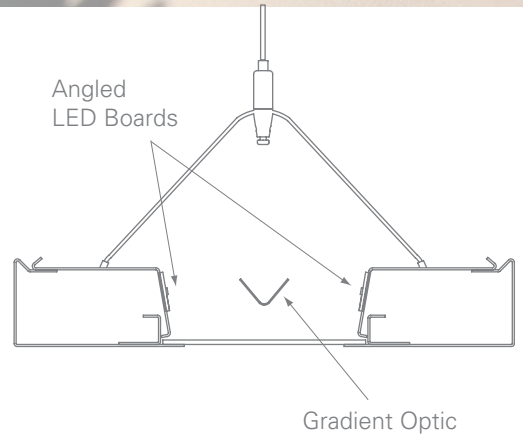
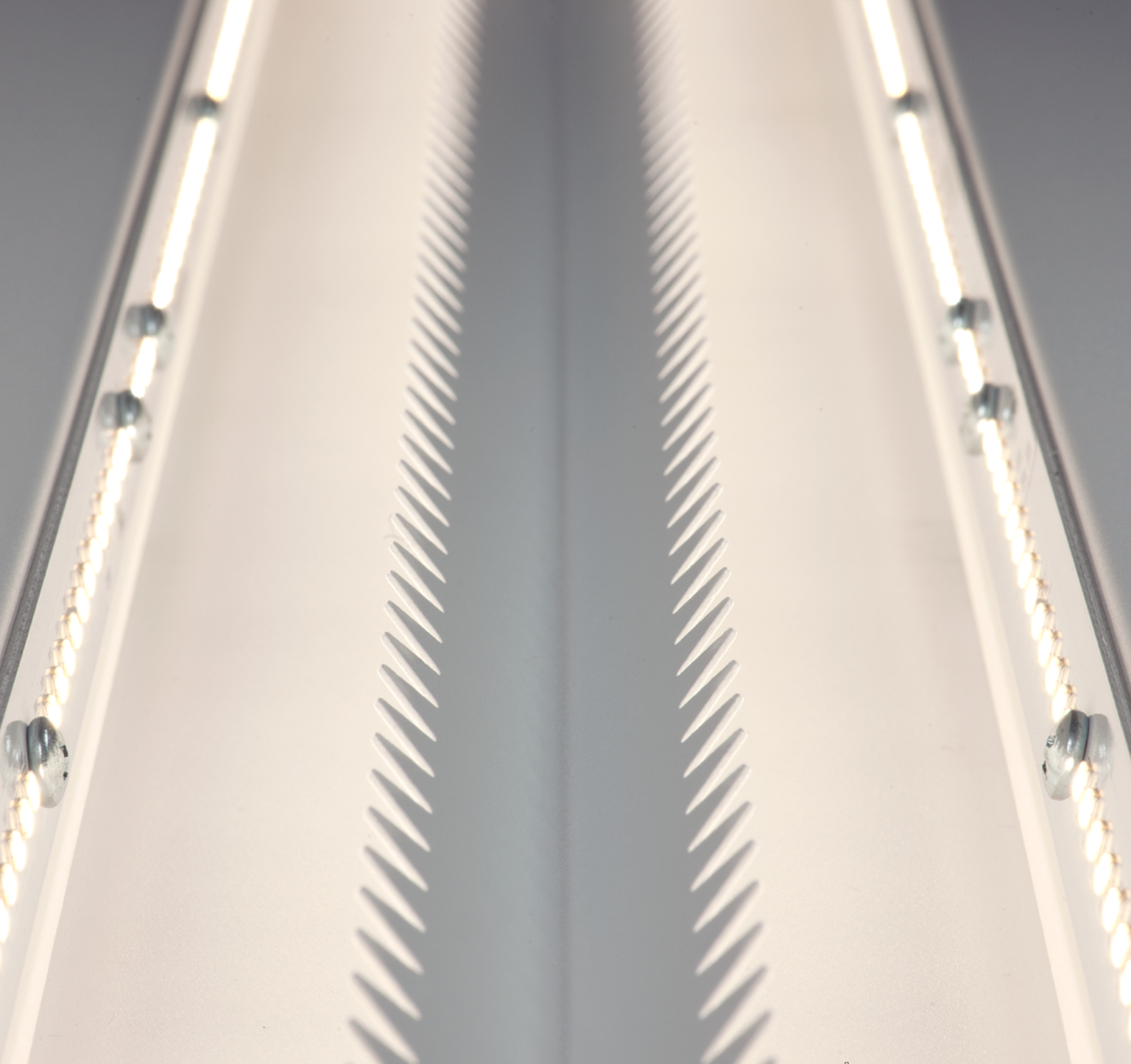

# GRADIENT OPTIC TECHNOLOGY

Focal Point cares about the details. We employ the critical evaluation required to get it right when transitioning existing fluorescent platforms to LED. Twelve LED features our Gradient Optic, a saw tooth band that diffuses the edges of the indirect distribution to prevent harsh lines on vertical surfaces. The Gradient Optic also directs light down through the lens, and dampens the brightness directly above the luminaire to allow for close-to-ceiling mounting. These thoughtful details help Twelve to be an integral part of creating comfortable and productive environments.

The curve shows the Gradient Optic effect:

- Main beam at 115° produces wide distribution for wide fixture spacings
- Consistent intensity from 110° - 135° produces a soft beam edge on walls & vertical surfaces
- Reduced intensity from 160° - 180° enables 12" suspension in low ceiling applications

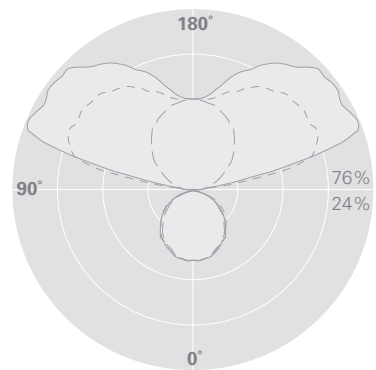

Before Gradient Optic  
Harsh line appears on vertical surfaces

Focal Point's Gradient Optic  
Creates smooth gradient transitions



# EVERYTHING + MORE

With Twelve LED, transitioning to new technology couldn't be easier. This high performance design delivers light in the same way as its fluorescent predecessor while offering substantial energy savings and remarkable lifetime. The perfect balance of direct and indirect light addresses the task and ambient functions of classroom, office and library applications. Broad indirect distribution lets luminaire spacings get wider, requiring fewer runs to do the job.

LAMP / LED OUTPUT	1T5	2T5	1T5HO	750LF	875LF	1000LF	1125LF	1250LF
DELIVERED LUMENS	2500	4952	4310	2801	3298	3786	4260	4679
SYSTEM WATTAGE	32	63	63	26	31	36	41	46
LPW	78	79	68	108	106	105	104	102

## 20' x 40'

LAMP / LED OUTPUT	SHIELDING	AVERAGE FOOTCANDLES	CEILING UNIFORMITY	WORKPLANE UNIFORMITY	WATTS/ SQ. FOOT	
10' CEILING, 18" Suspension, 12' spacing (2 rows)						
LED	1T5HO	MicroGlow (M1)	41.1	6.5	3.6	1.05
	750LF	Acrylic	30.9	6.7	3.0	0.43
	875LF	Acrylic	36.4	6.8	3.0	0.52
	1000LF	Acrylic	41.8	6.8	3.0	0.60
	1000LF	MicroGlow	41.8	7.4	3.2	0.60
10' CEILING, 24" Suspension, 12' spacing (2 rows)						
LED	1250LF	Acrylic	48.5	5.5	2.6	0.77

## 30' x 30'

LAMP / LED OUTPUT	SHIELDING	AVERAGE FOOTCANDLES	CEILING UNIFORMITY	WORKPLANE UNIFORMITY	WATTS/ SQ. FOOT	
8' CEILING, 12" Suspension, 12' spacing (2 rows)						
LED	1T5HO	MicroGlow (M1)	44.9	6.9	2.7	1.26
	750LF	Acrylic	34.9	6.9	2.2	0.52
	875LF	Acrylic	41.1	6.8	2.2	0.62
12' CEILING, 36" Suspension, 14' spacing (2 rows)						
LED	2T5	MicroGlow (M1)	30.7	5.2	3.2	1.08
	1125LF	Acrylic	27.9	5.0	2.4	0.7
	1250LF	Acrylic	30.7	5.0	2.4	0.8

# RIGHT LIGHT™

Our Right Light™ system provides 5 standard output levels—**3000, 3500, 4000, 4500** and **5000** delivered lumens per 4' section. We will always support these output levels for Twelve LED, so you will never have to rethink or recalculate your design. Request alternate levels within the standard range for even more control of light levels and energy consumption. Factory-programmable drivers enable this exceptional versatility, so you can deliver the Right Light for any space.



# DETAILS

## suspended

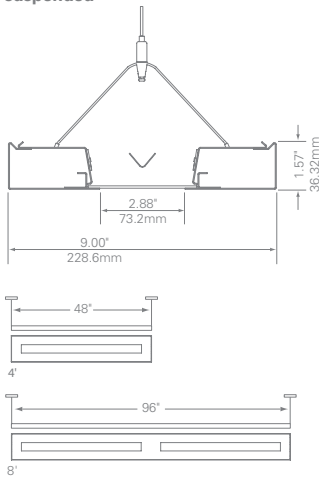

## wall mount

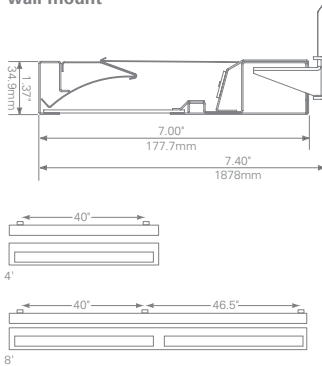

# LUMEN MAINTENANCE

Twelve LED is designed to last. Cool running mid-power LEDs are projected to maintain 90% of their initial output for 100,000 hours.

### PER TM-21 CALCULATOR

Calculated L90	100,000 hrs
Reported L90	>37,000 hrs



 Follow @focalpointlight

PHOTO CREDITS: University Center - The New School, New York, NY.  
Architect: SOM. Photographer: James Ewing.

©2015 Focal Point, LLC., 4141 S. Pulaski Road, Chicago, IL 60632 | T 773.247.9494  
www.focalpointlights.com All rights reserved. "Focal Point", "The Art of Light",  
"Right Light" and the light-ray graphic are trademarks or registered trademarks of  
Focal Point, LLC. Visit www.focalpointlights.com for details on our entire catalog.

9/15 MKT#1111

# ORDERING

<b>fixture series</b>		_____
Twelve LED Suspended	FTWLS	
Twelve LED Wall Mount	FTWLW	
<b>shielding</b>		_____
Acrylic Diffuser	AC	
MicroGlow prismatic lens	MG	
<b>lumen output</b>		
625 Lumens per foot (FTWLS only)	625LF	
750 Lumens per foot	750LF	
875 Lumens per foot	875LF	
1000 Lumens per foot (FTWLS only)	1000LF	
1125 Lumens per foot (FTWLS only)	1125LF	
1250 Lumens per foot (FTWLS only)	1250LF	
<b>color temperature</b>		_____
3000K	30K	
3500K	35K	
4000K	40K	
<b>circuits</b>		<b>1C</b>
Single Circuit	1C	
<b>voltage</b>		_____
120 Volt	120	
277 Volt	277	
UNV Volt	UNV	
<small>(Cannot be specified with EM option)</small>		
<b>driver</b>		_____
0-10V - 10% Dimming	LD1	
Lutron A-Series		
1% EcoSystem Digital	L3D	
<small>(Not available with 1250LF. Consult factory for 3-wire control)</small>		
DALI - 10% Dimming (FTWLW only)	DD1	
DALI - 0% Dimming (FTWLW only)	DZ1	
Step Dimming (FTWLW only)	LDA	
<b>mounting</b>		_____
12" Cable Suspension	J12	
24" Cable Suspension	J24	
48" Cable Suspension	J48	
96" Cable Suspension	J96	
<small>(Specify one of the following in place of "J" C - for 5" canopies at non-feed locations. CS - for sloped ceilings.)</small>		
Stem Mount	S_	
<small>(Specify stem length in inches Standard stem lengths 6, 12, 18, 24, 36, 48". White stems and canopies supplied standard.)</small>		
Wall Mount	WM	
<b>factory options</b>		_____
<small>(FTWLS only)</small>		
Dust Cover	DC	
Emergency Circuit	EC	
Emergency Battery	EM	
<small>(Sensor options available—consult factory)</small>		
<b>finish</b>		_____
Matte Satin White	WH	
Titanium Silver	TS	
<b>fixture run length</b>		_____
4'	4'	
8'	8'	
12' (8'+4')	12'	
16' (8'+8')	16'	
20' (8'+4'+8')	20'	
24' (8'+8'+8')	24'	
<small>(Individual units may not be field modified for continuous row mount)</small>		