

Seem® 1 Trio Mud-In-Drywall

FSM1F-T-XF



FOCAL POINT®



BEFORE YOU BEGIN

- Luminaires must be installed by a qualified electrician (check with local and national codes for proper installation).
- To prevent electrical shock, disconnect electrical supply before installation or servicing.
- Contractor is responsible for adequately reinforcing walls and/or ceilings to support fixture weight.
- Focal Point, LLC accepts no responsibility for inadequately reinforced walls and/or ceilings.
- The information contained in this drawing is the sole property of Focal Point, LLC. Any reproduction in part or whole without the written permission of Focal Point, LLC is prohibited.

INSTRUCTION KEY



ATTENTION



SEE ADDITIONAL INSTRUCTIONS



POWER OFF



POWER ON

COMPONENT KEY

FOCAL POINT

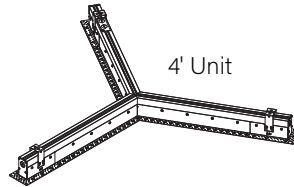

4' Unit

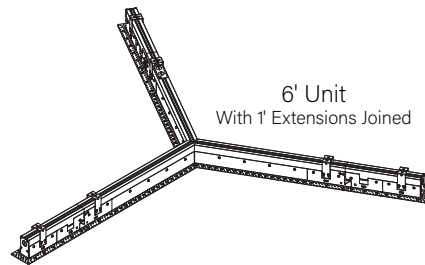

6' Unit
With 1' Extensions Joined



1' Extension

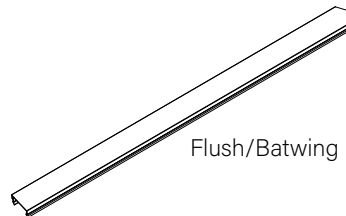

Flush/Batwing Lens

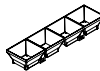

Louver



Point Source

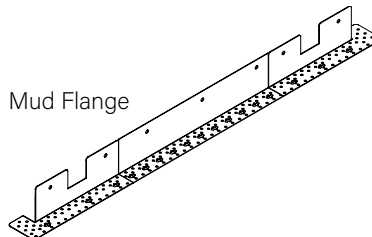

Mud Flange

SHIPPED INSTALLED



Reflector Screw
(72026)

(8-18 x 1/4 SELF TAPPING SCREW)



Tie-Wire Bracket Screw
(72010)

(8-18 x 1/4 SELF TAPPING SCREW)

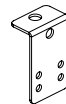

Tie Wire Bracket
(A38635-01)

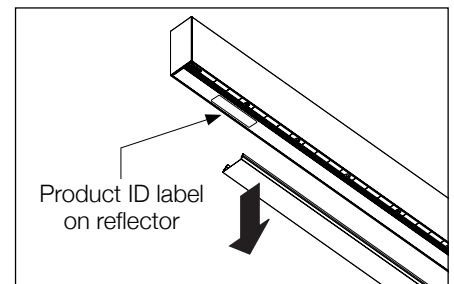

Product ID label
on reflector



SEE **PAGES 2-4** FOR
POST-DRYWALL INSTALLATION

SEE **PAGES 4-5** FOR
PRE-DRYWALL INSTALLATION

MOUNTING DIMENSIONS

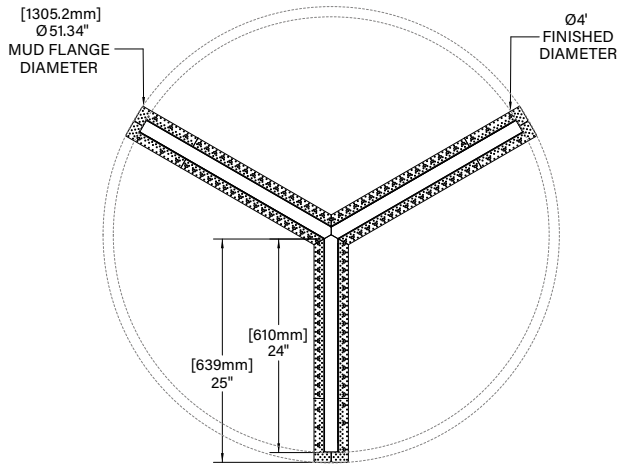

4' DIAMETER - BOTTOM VIEW

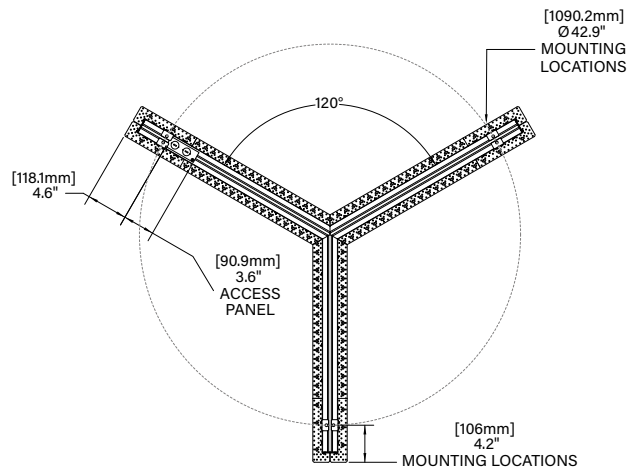

4' DIAMETER - TOP VIEW

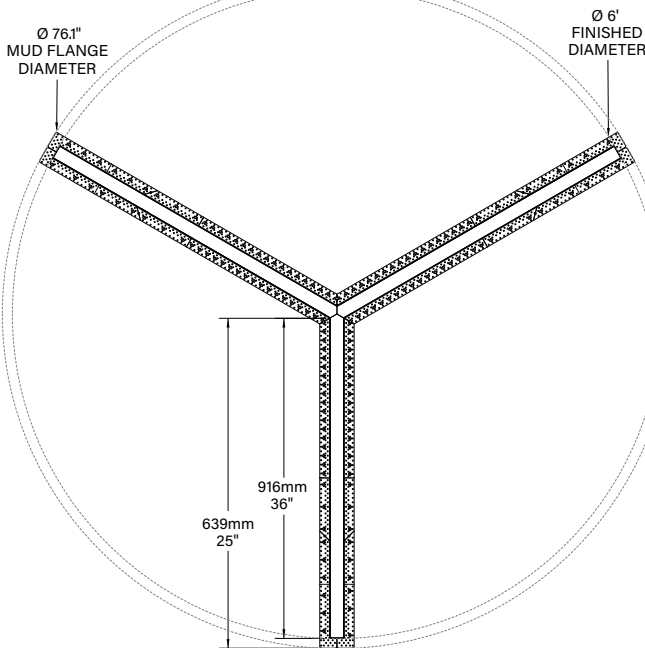

6' DIAMETER - BOTTOM VIEW

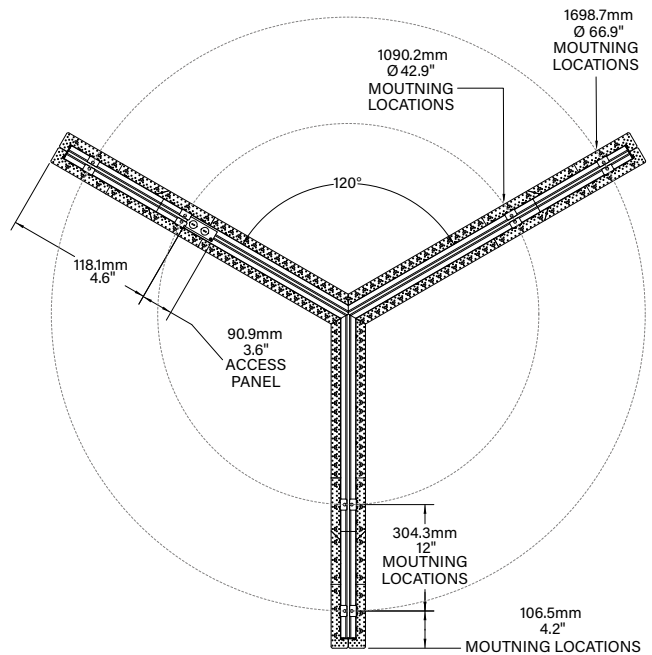

6' DIAMETER - TOP VIEW

POST-DRYWALL INSTALLATION



**2"X6" FRAMING
REQUIRED ON BOTH SIDES
OF HOUSING**

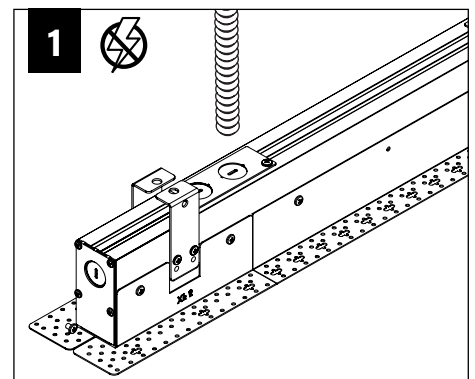
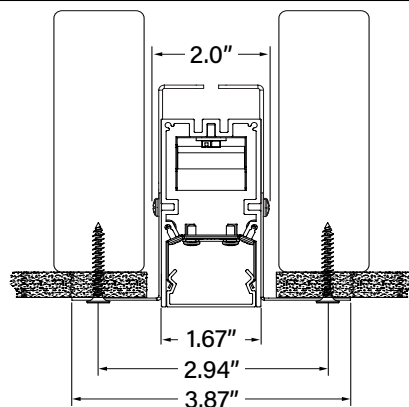

MAKE ELECTRICAL CONNECTION

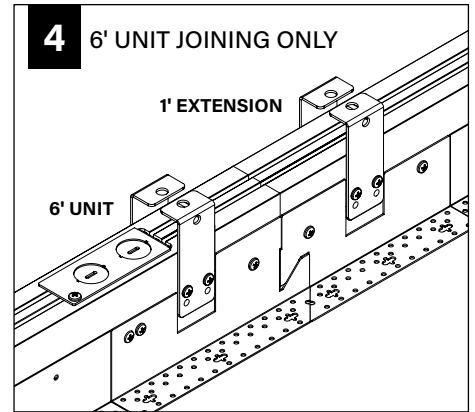
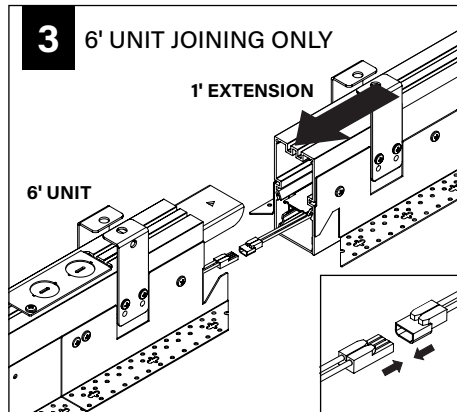
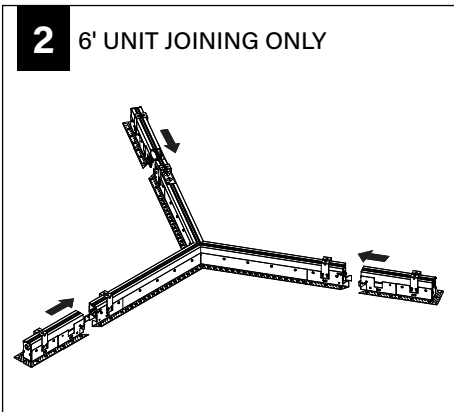

⚠ LENS MUST BE INSTALLED PRIOR TO DRYWALL INSTALLATION

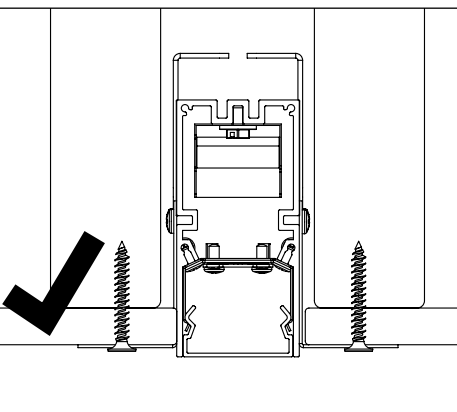
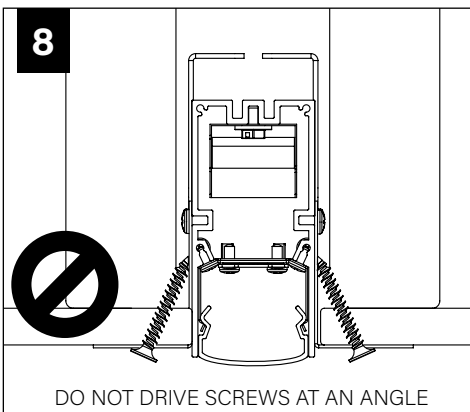
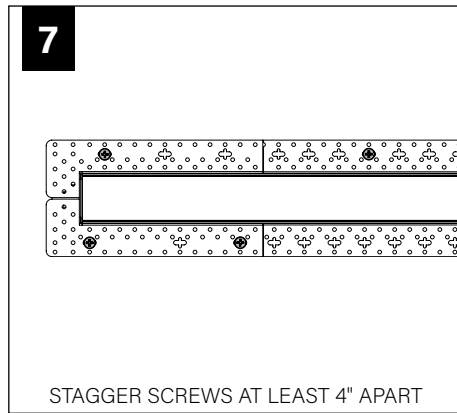
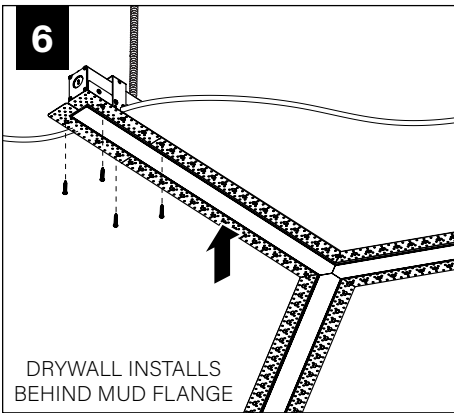
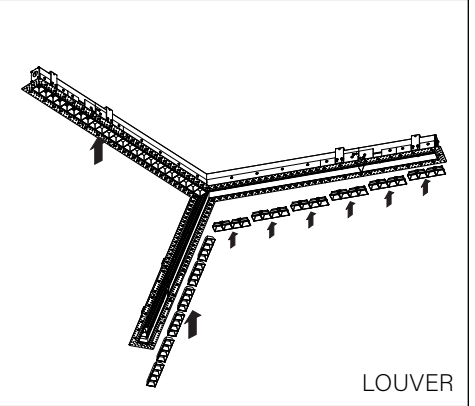
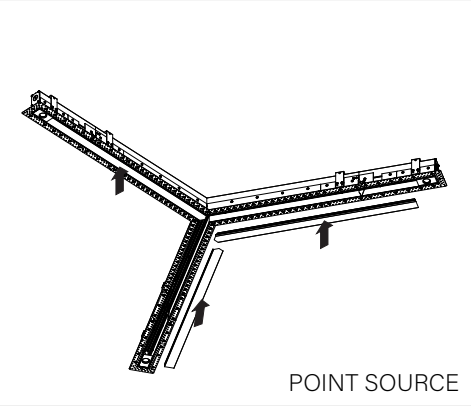
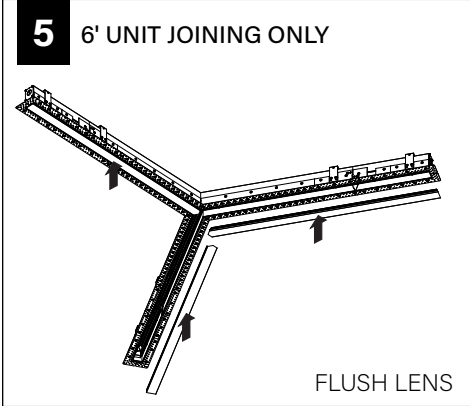

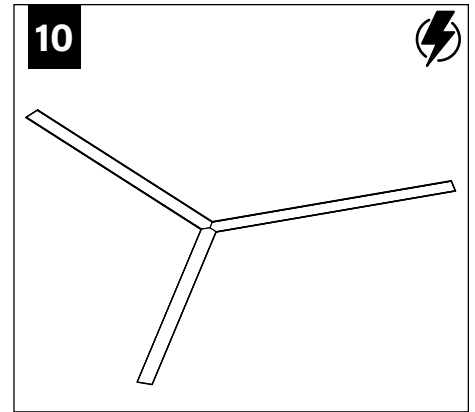
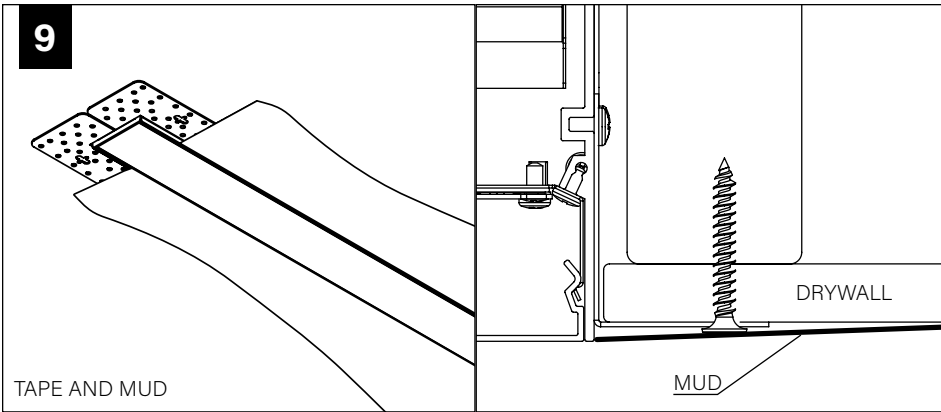

PRE-DRYWALL INSTALLATION

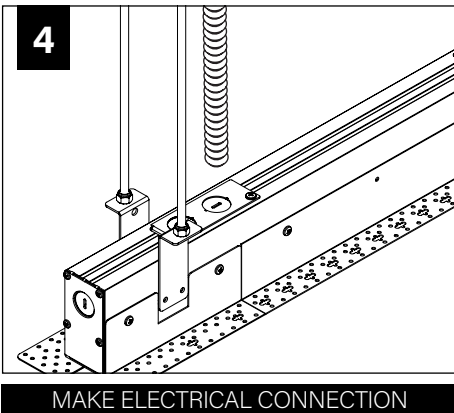
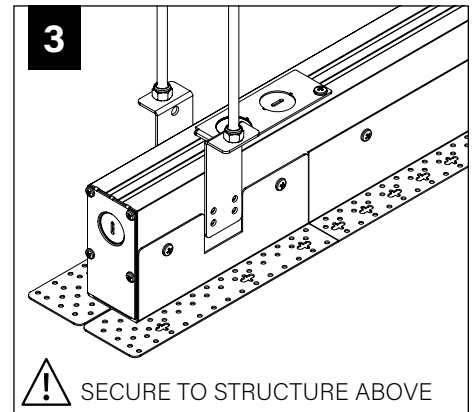
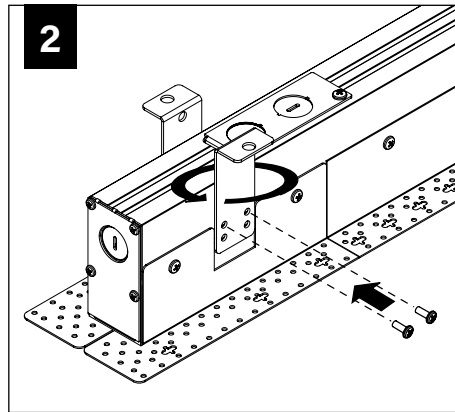
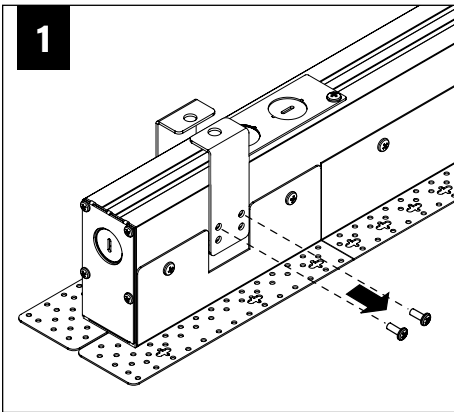

MAKE ELECTRICAL CONNECTION

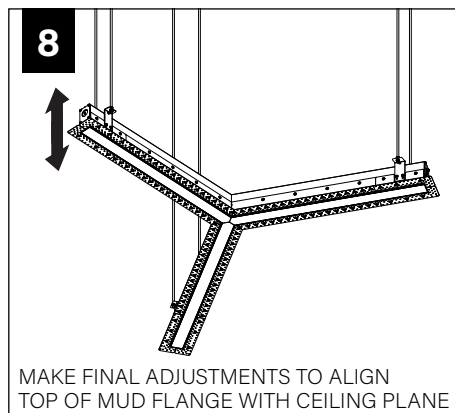
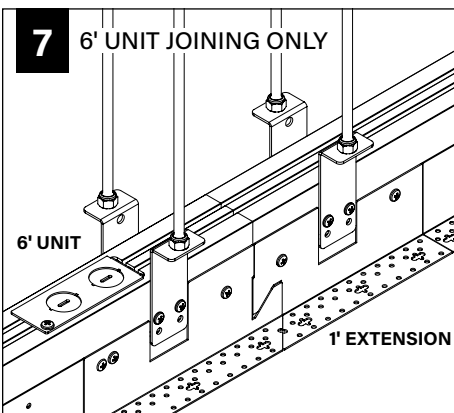
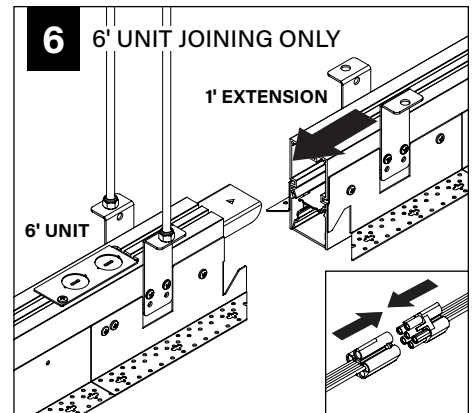
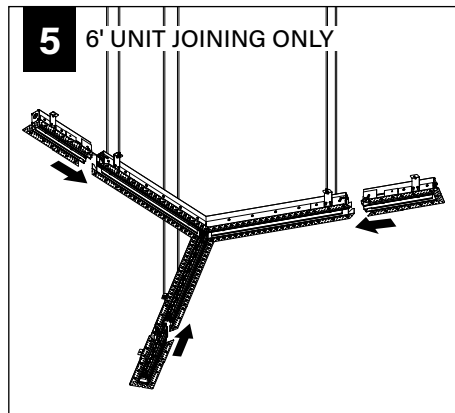

⚠ LENS MUST BE INSTALLED PRIOR TO DRYWALL INSTALLATION

9 6' UNIT JOINING ONLY

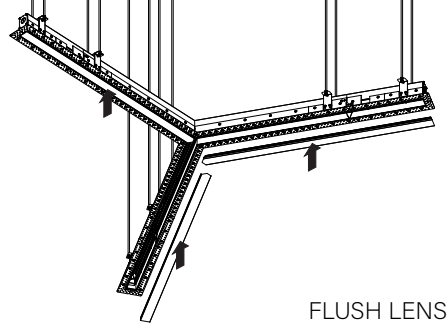

FLUSH LENS

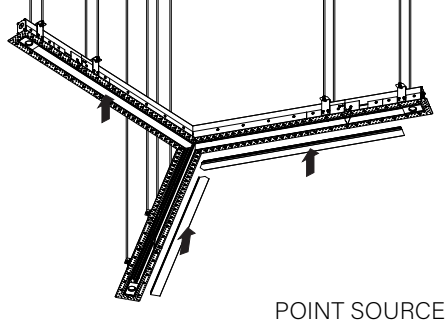

POINT SOURCE

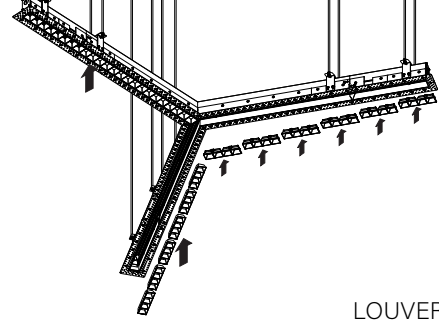

LOUVER

10

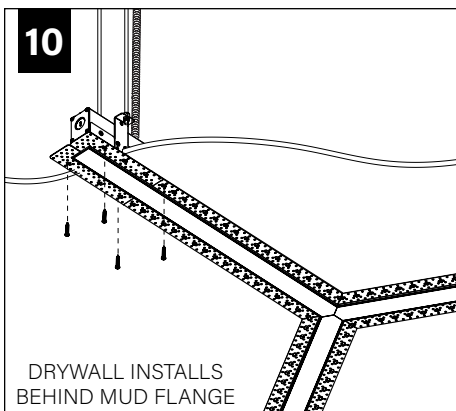

DRYWALL INSTALLS BEHIND MUD FLANGE

11



STAGGER SCREWS AT LEAST 4" APART

12

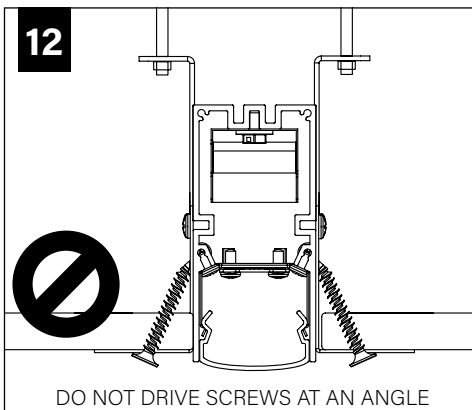

DO NOT DRIVE SCREWS AT AN ANGLE

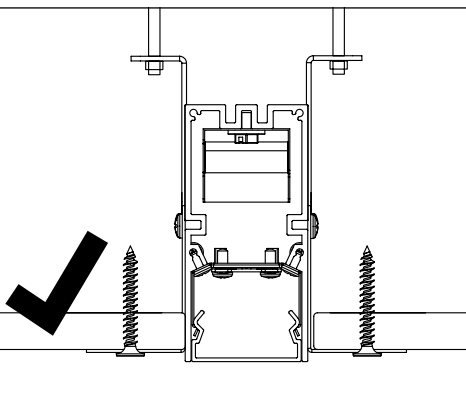

13

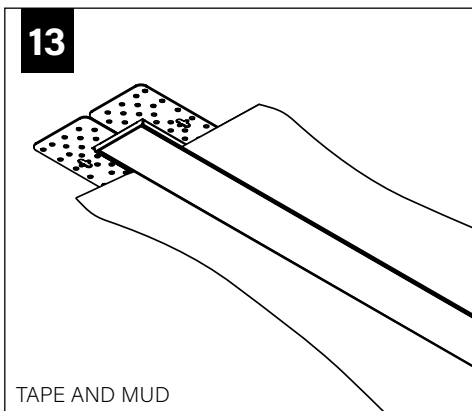

TAPE AND MUD

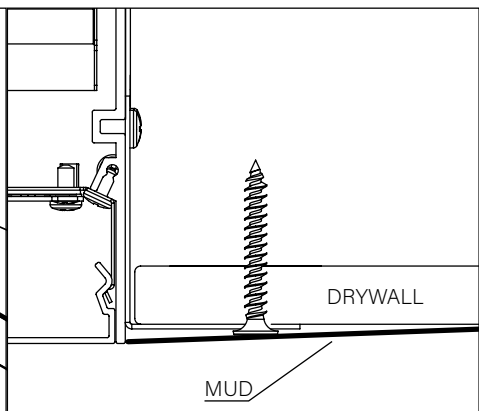

DRYWALL

MUD

14

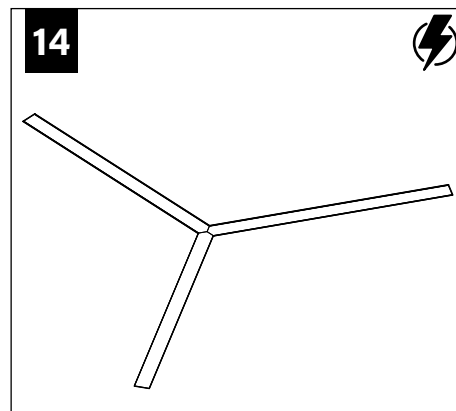

DRIVER SERVICE

FLUSH LENS

1

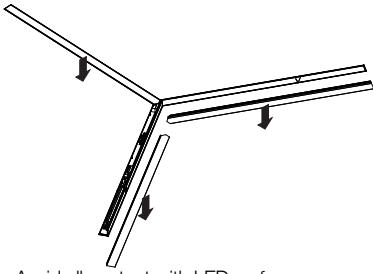

! Avoid all contact with LED surface, LEDs are easily damaged!

2

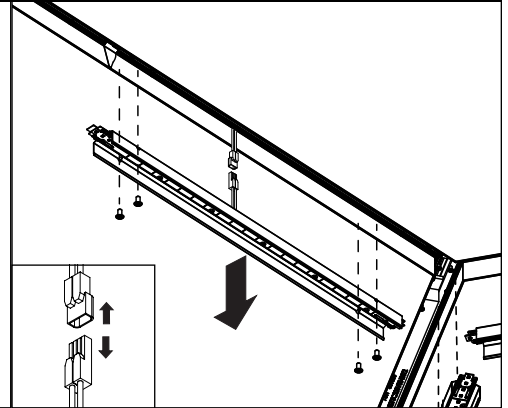
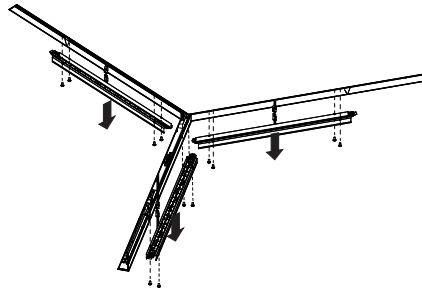

1

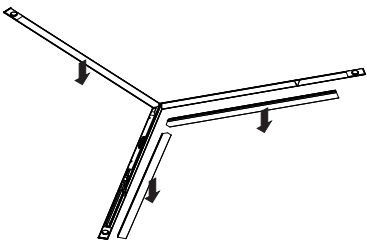

! Avoid all contact with LED surface, LEDs are easily damaged!

2

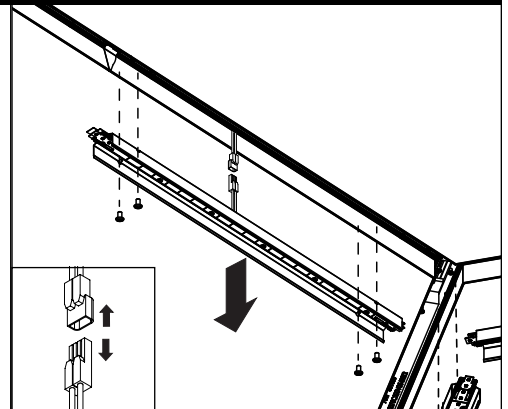
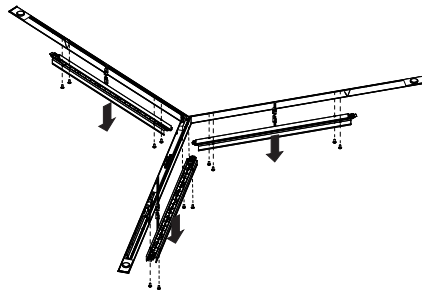

LOUVER

1a

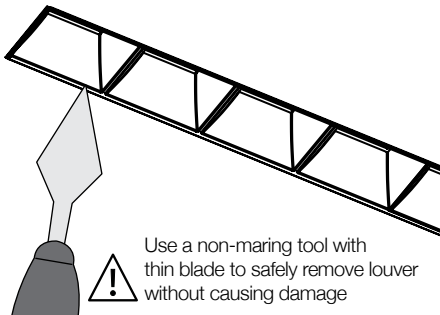

! Use a non-marring tool with thin blade to safely remove louver without causing damage

1b

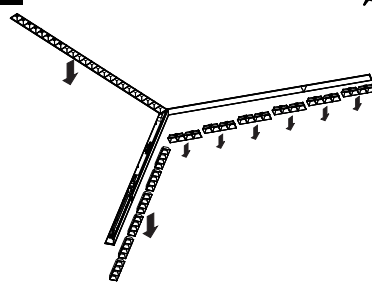

! Avoid all contact with LED surface, LEDs are easily damaged!

2

