

skydome™ 1x1

FSD-11



FOCAL POINT®

FOCAL POINT

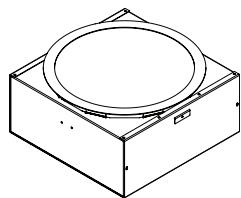

OPTIONAL - SOLD SEPARATELY

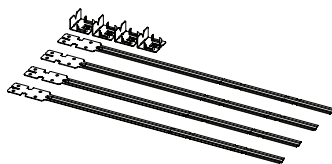

KEY



POWER OFF



POWER ON



ATTENTION



**LUMINAIRE MUST BE INSTALLED PRIOR TO DRYWALL CEILING
NOT RECOMMENDED FOR ON GRID INSTALLATION**

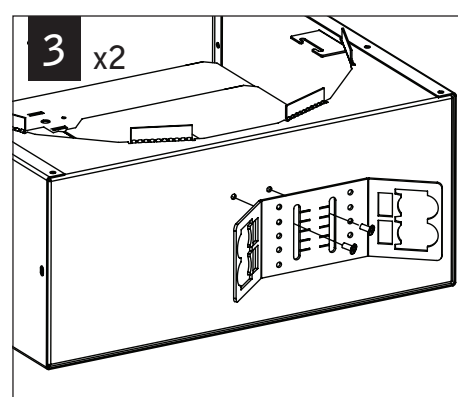
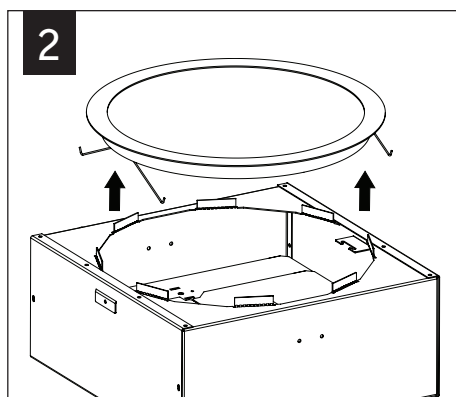
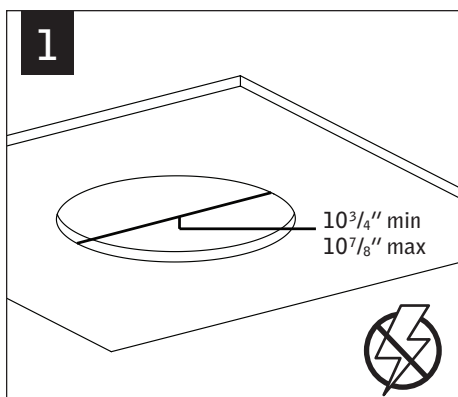

GRID - 1/2" CONDUIT & CLIP (BY OTHERS)

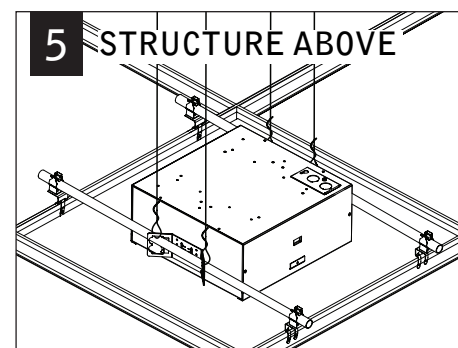
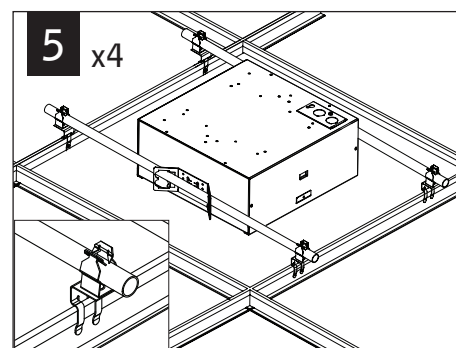
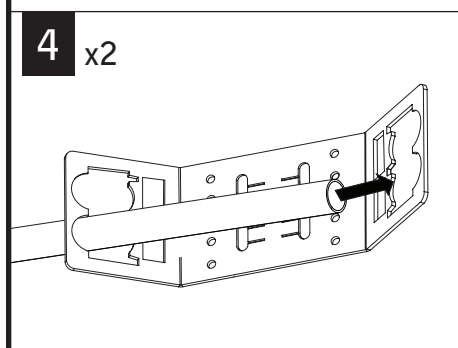

GRID - BAR HANGERS (SOLD SEPARATELY)

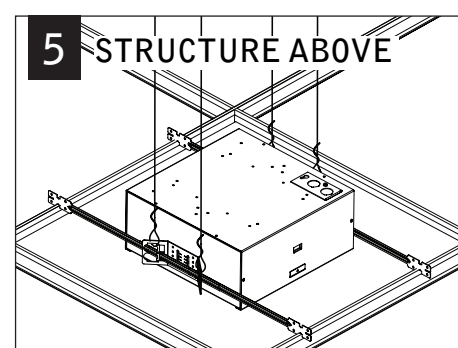
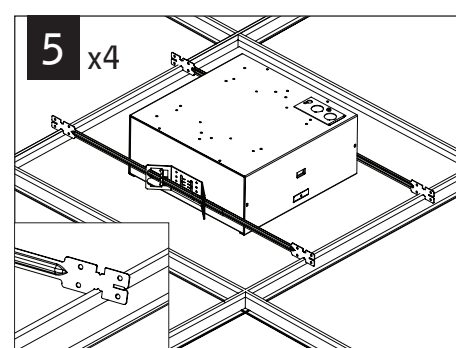
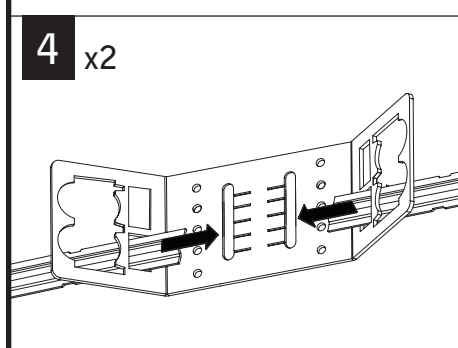

Luminaires must be installed by a qualified electrician (check with local and national codes for proper installation).
To prevent electrical shock, disconnect electrical supply before installation or servicing.

DRYWALL - BAR HANGERS (SOLD SEPARATELY)

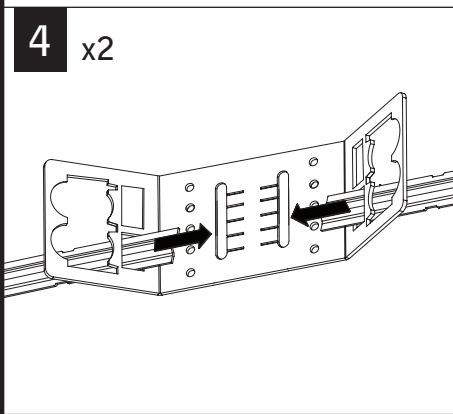

METAL STUDS

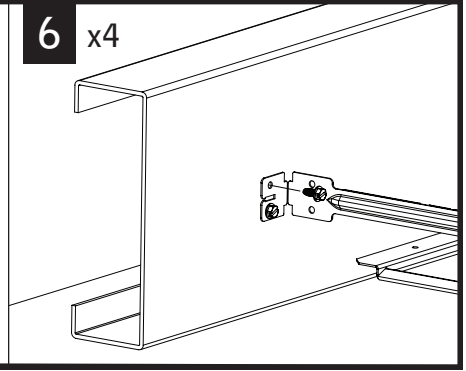
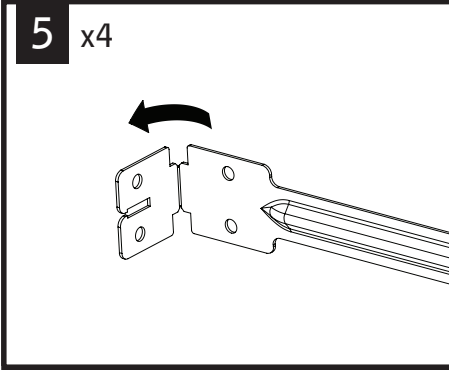

WOOD STUDS

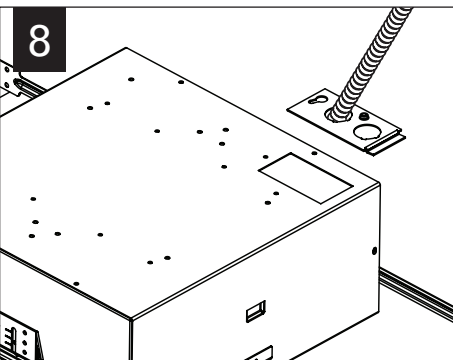
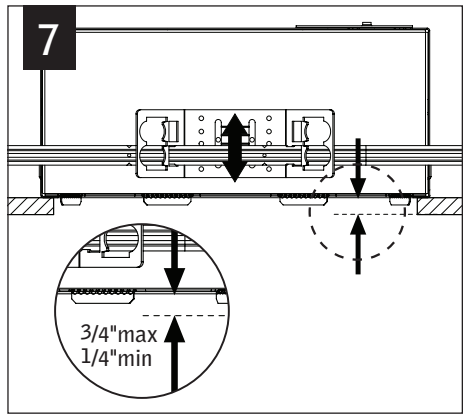
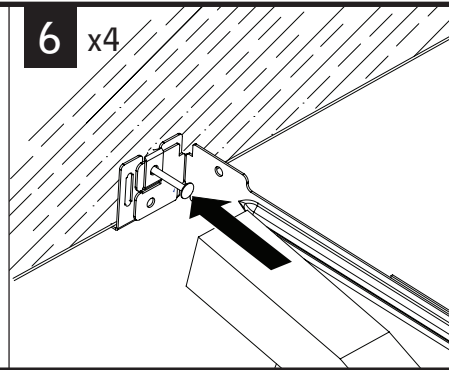
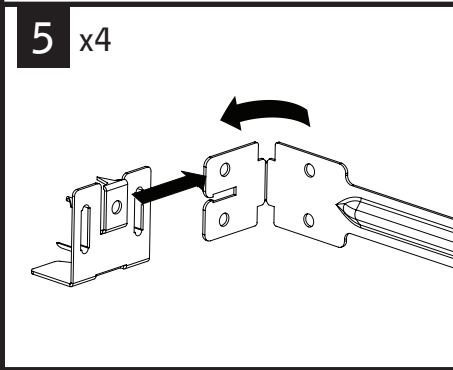

MAKE ELECTRICAL CONNECTIONS

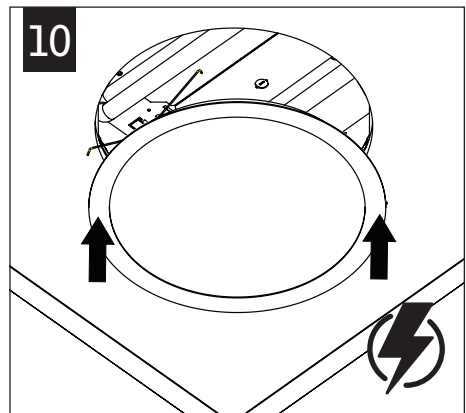
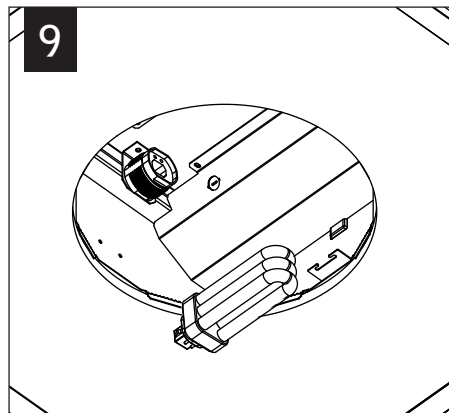

BALLAST SERVICE

- 1** Remove Trim Assembly
- 2** Remove Lamp
- 3** Remove Ballast Covers

	CFL	Biax/Circline	
			 Emergency Battery

Luminaires must be installed by a qualified electrician (check with local and national codes for proper installation).
To prevent electrical shock, disconnect electrical supply before installation or servicing.

EMERGENCY



SEE BATTERY MANUFACTURER
INSTRUCTIONS

EMERGENCY MAXIMUM MOUNTING HEIGHT:
8.00'