

ID+ Cylinder Pendant

FLCY3 | FLCY4



FOCAL POINT®



BEFORE YOU BEGIN

- Luminaires must be installed by a qualified electrician (check with local and national codes for proper installation).
- To prevent electrical shock, disconnect electrical supply before installation or servicing.
- Contractor is responsible for adequately reinforcing walls and/or ceilings to support fixture weight.
- Focal Point, LLC accepts no responsibility for inadequately reinforced walls and/or ceilings.
- The information contained in this drawing is the sole property of Focal Point, LLC. Any reproduction in part or whole without the written permission of Focal Point, LLC is prohibited.

INSTRUCTION KEY



ATTENTION



SEE ADDITIONAL INSTRUCTIONS



POWER OFF



POWER ON

COMPONENT KEY

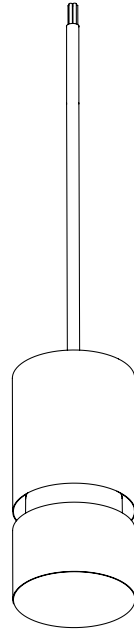

SHALLOW CANOPY

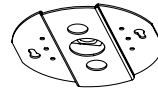

J-BOX
MOUNTING BRACKET

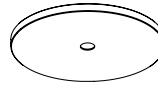

SHALLOW CANOPY

POWER CANOPY

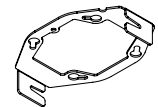

J-BOX
MOUNTING
BRACKET

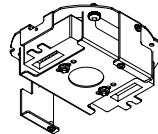

DRIVER
CARRIAGE

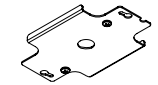

POWER CORD
MOUNTING
BRACKET

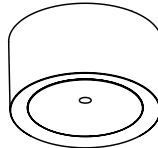

POWER
CANOPY

SWIVEL STEM MOUNT

Shipped Assembled

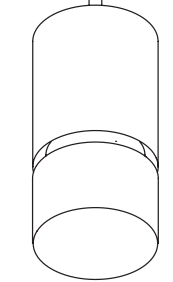
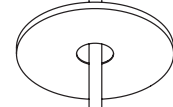

INSTALL 4" OCTAGONAL J-BOX (BY OTHERS)

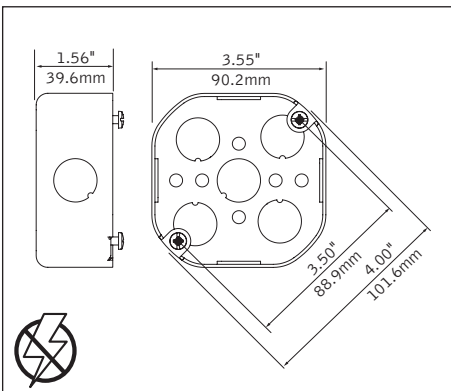

EMERGENCY



PRIOR TO LUMINAIRE INSTALLATION, SEE **PAGE 6** FOR EMERGENCY INSTALLATION INSTRUCTIONS.

MOUNTING TYPE



PROCEED TO LUMINAIRE INSTALLATION
SHALLOW CANOPY, PAGE 2
POWER CANOPY, PAGE 3
SWIVEL STEM, PAGE 4

SHALLOW CANOPY INSTALLATION

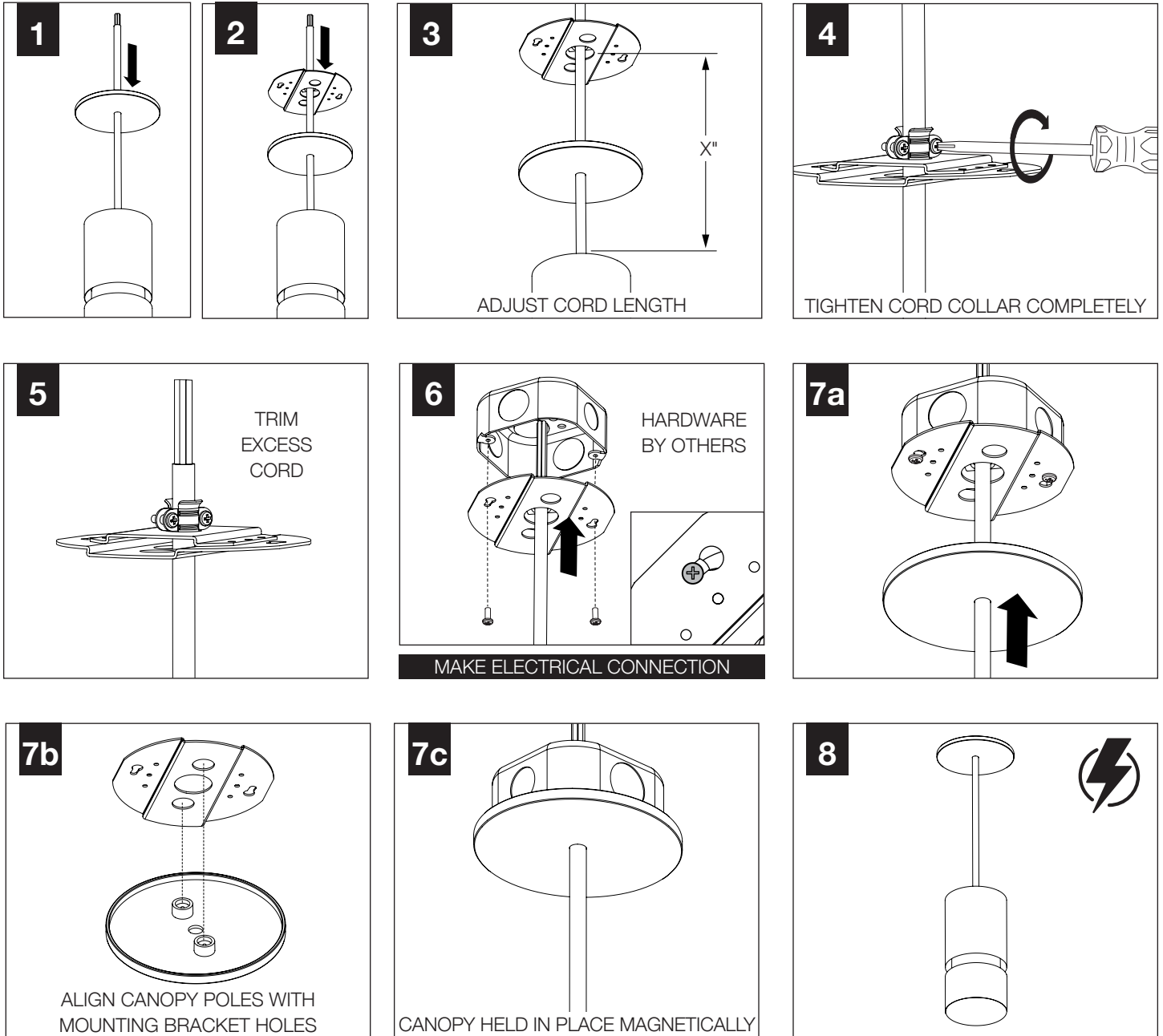

SHALLOW CANOPY DRIVER SERVICE

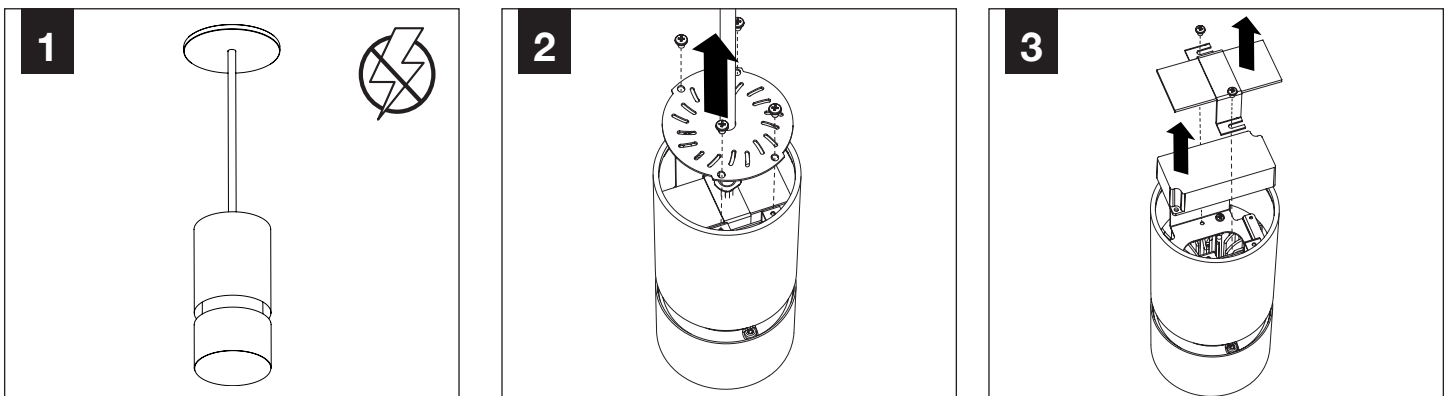

POWER CANOPY INSTALLATION

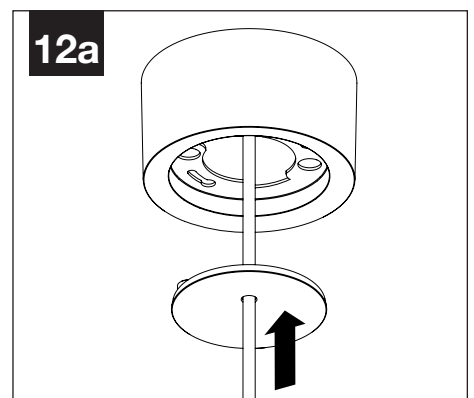
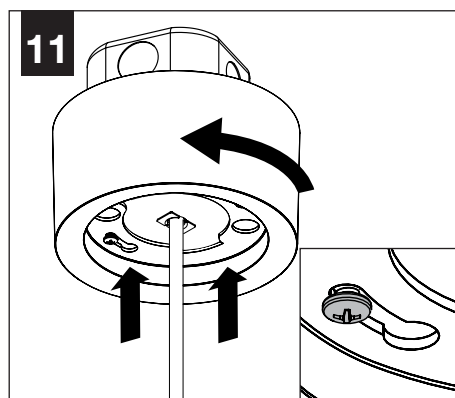
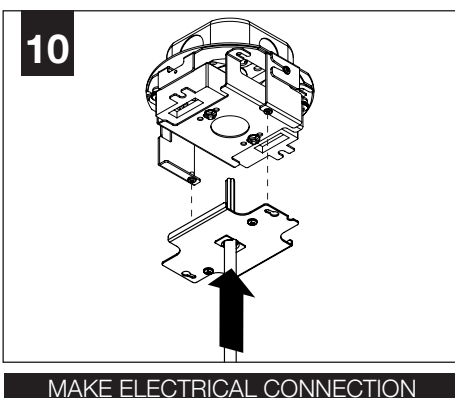
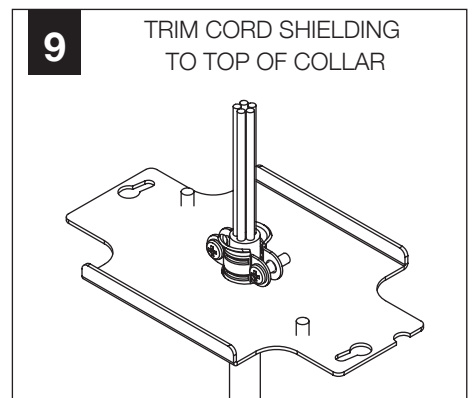
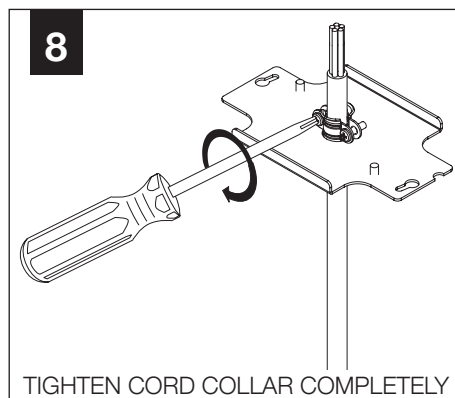
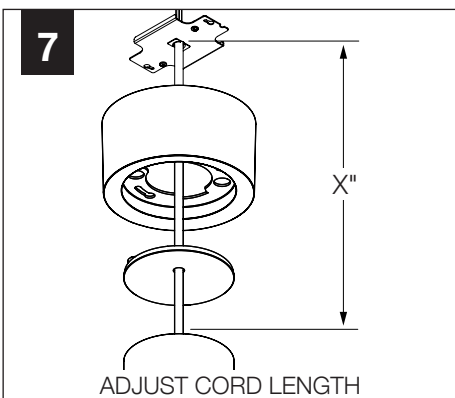
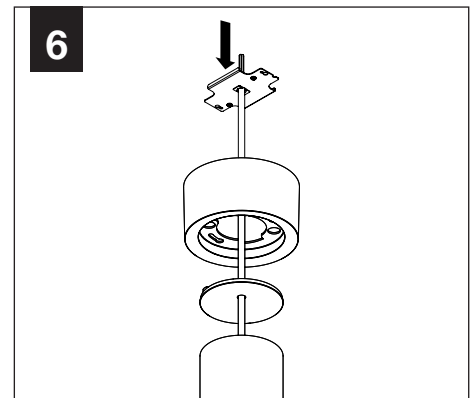
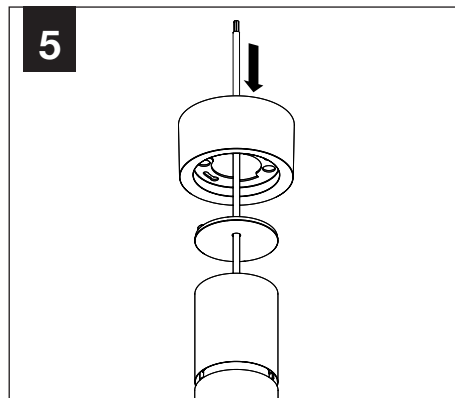
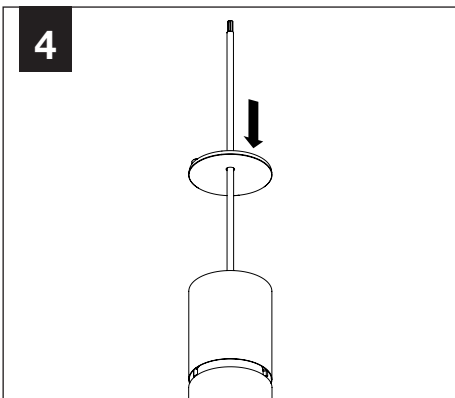
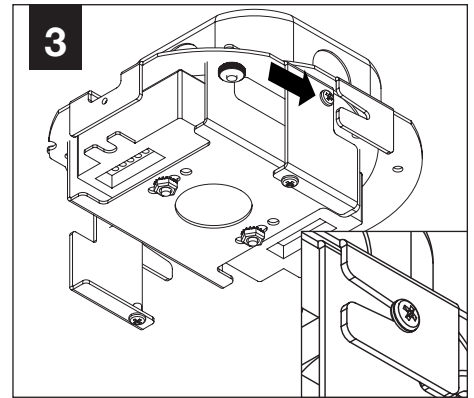
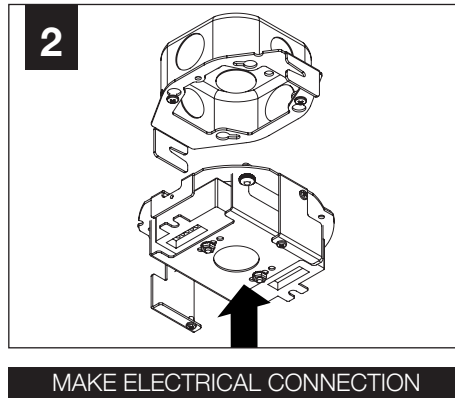
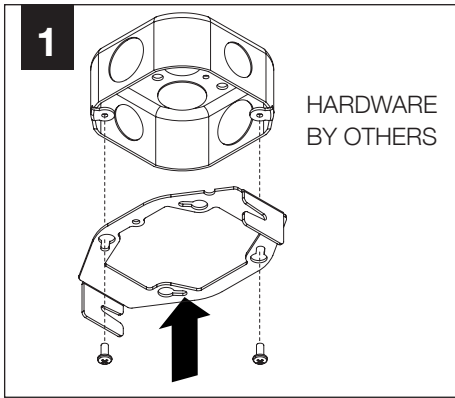

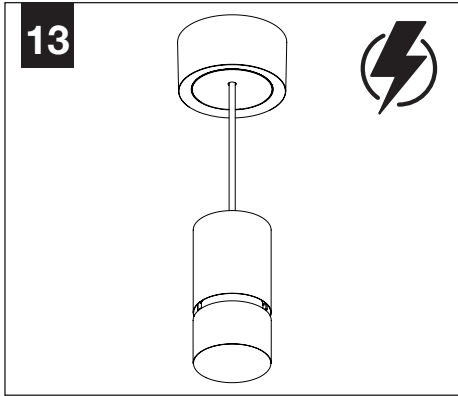
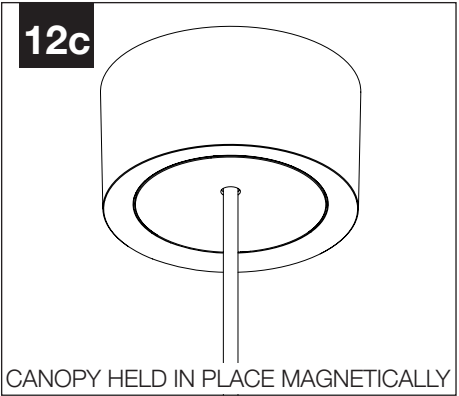
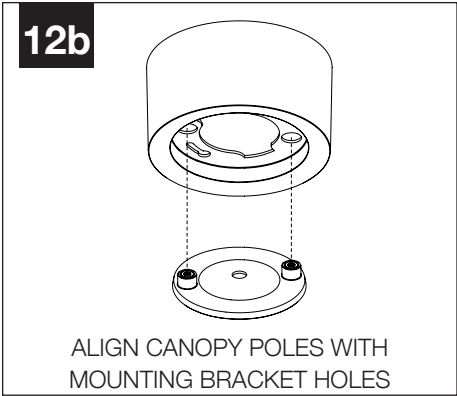

POWER CANOPY DRIVER SERVICE

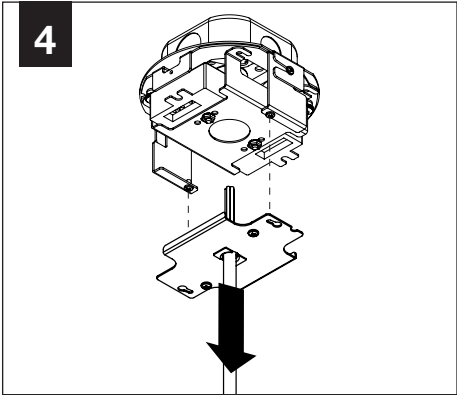
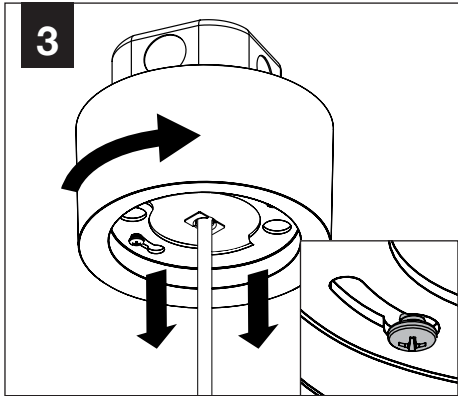
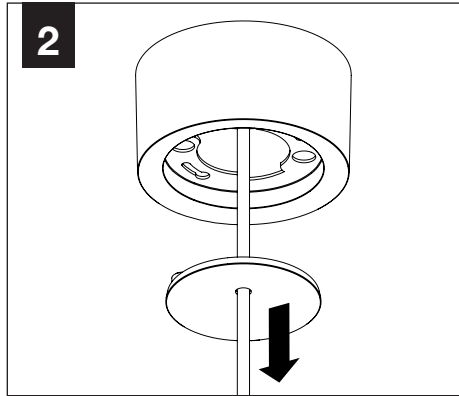
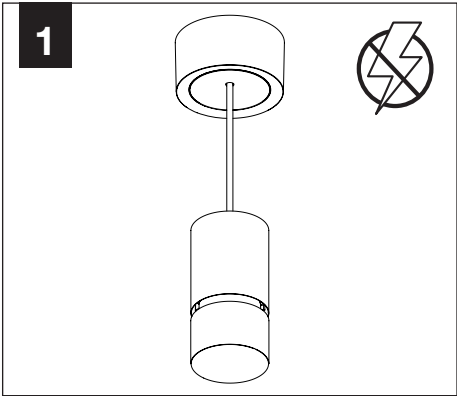

SWIVEL STEM INSTALLATION

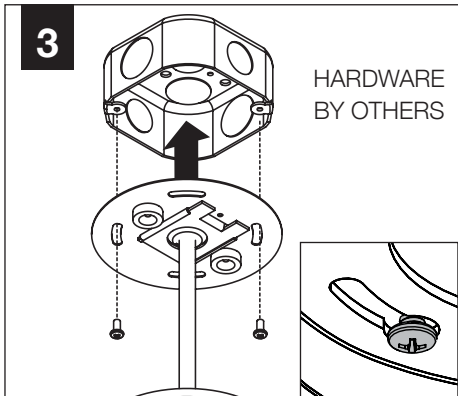
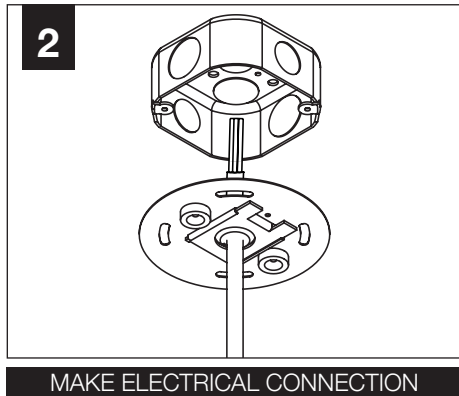
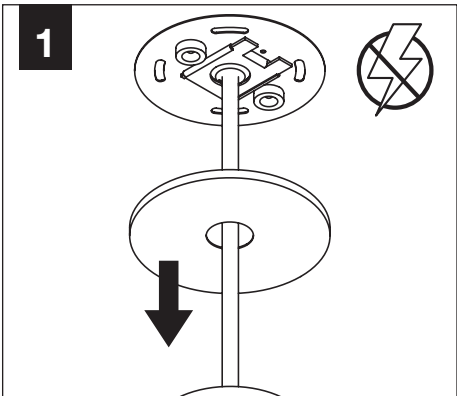

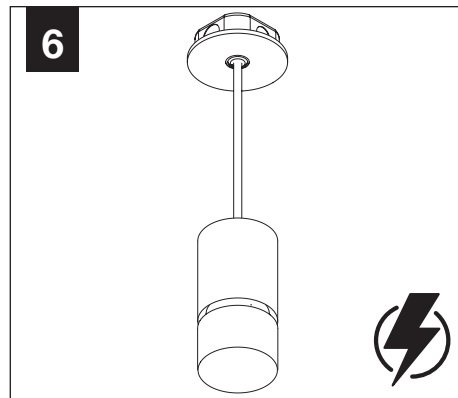
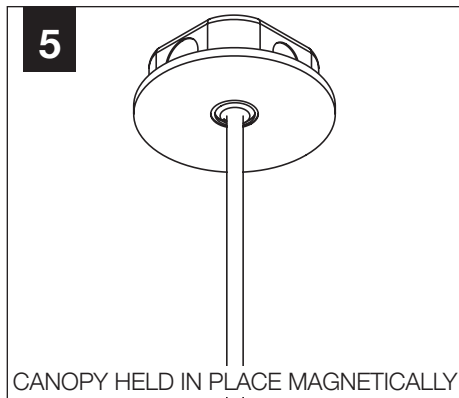
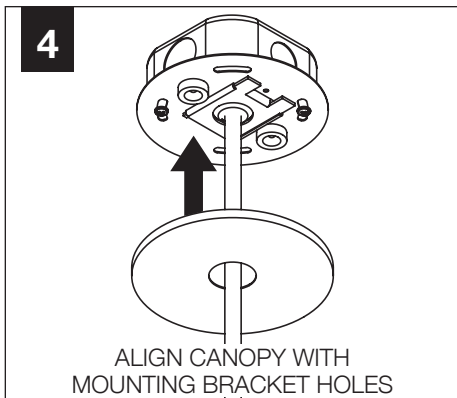

OPTIC SERVICE

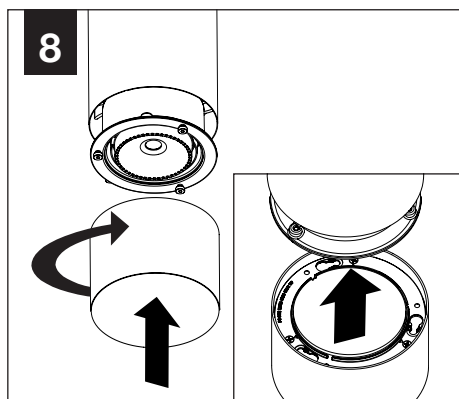
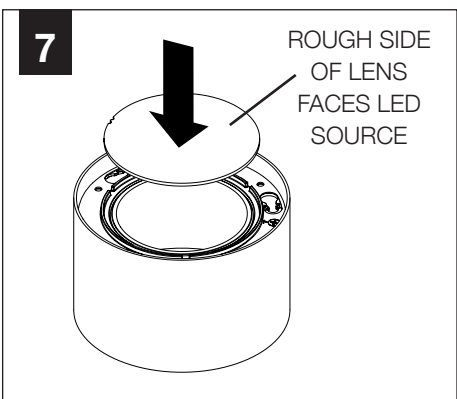
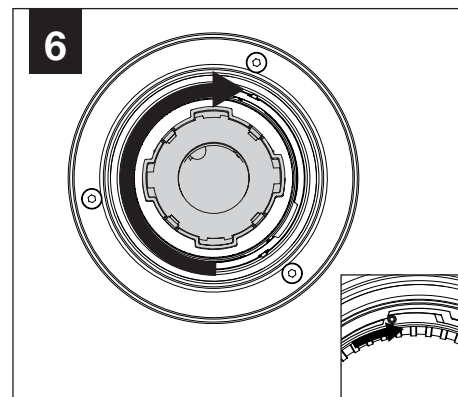
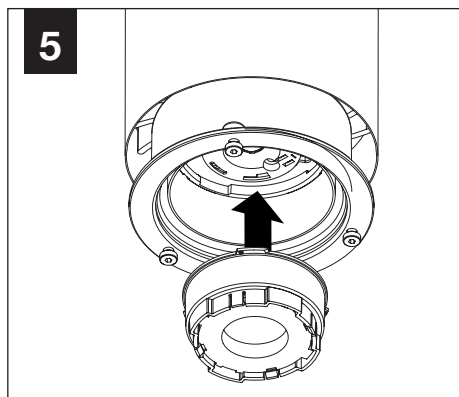
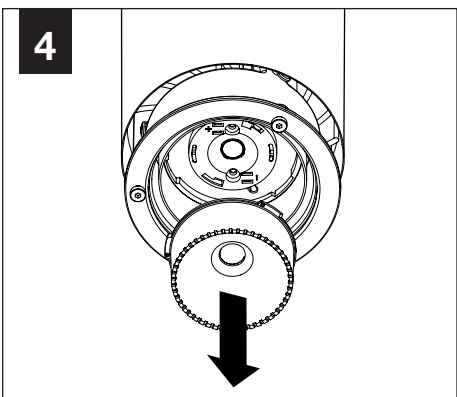
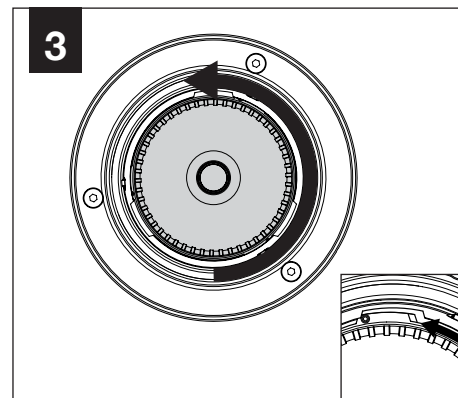
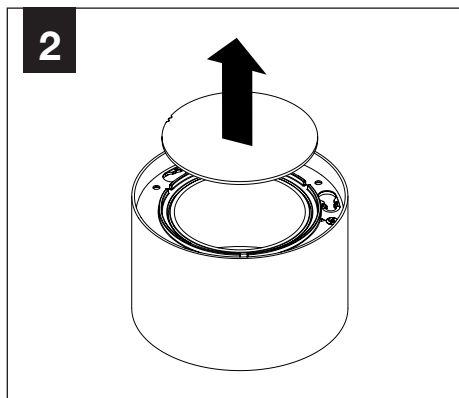
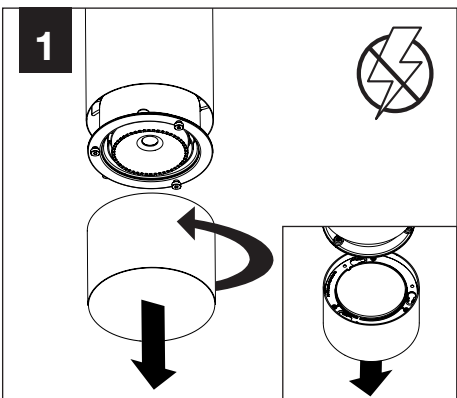

EMERGENCY



SEE BATTERY MANUFACTURER
INSTRUCTIONS

EMERGENCY MAXIMUM MOUNTING HEIGHT:

3.5" CYLINDERS - 16.98'

4.5" CYLINDERS - 16'

1

HARDWARE
BY OTHERS

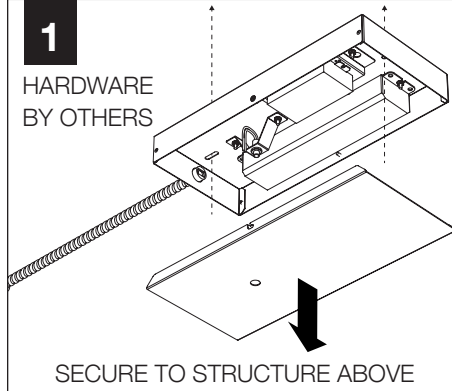

SECURE TO STRUCTURE ABOVE

2

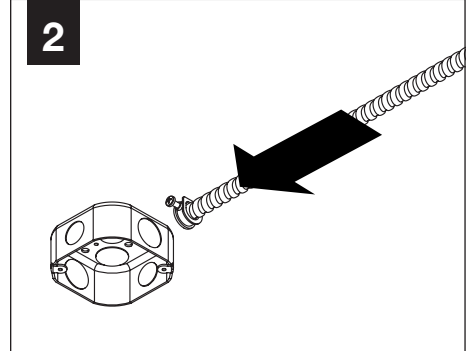

MAKE ELECTRICAL CONNECTION

3

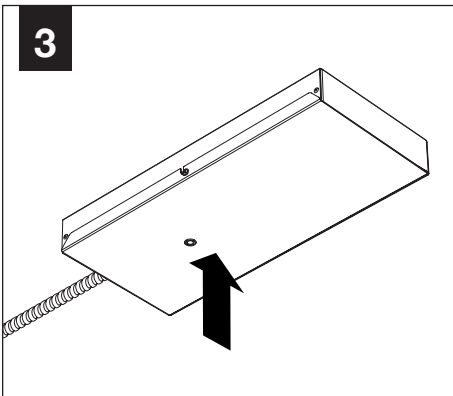

4

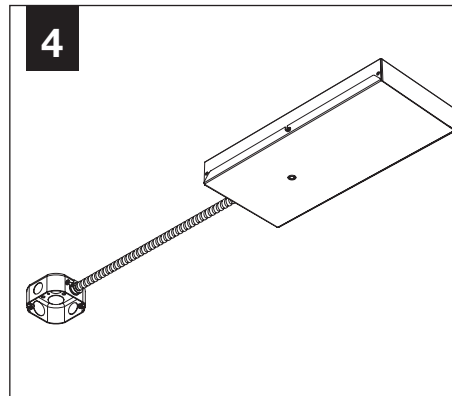

PROCEED TO
LUMINAIRE INSTALLATION
SHALLOW CANOPY, PAGE 2
POWER CANOPY, PAGE 3
SWIVEL STEM, PAGE 4