

ID+ 4.5" x 4.5"

LED DOWNLIGHT



FOCAL POINT®



solite lens option



clear diffuse



warm diffuse



white



clear diffuse & white flange

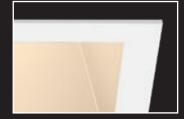

warm diffuse & white flange



black

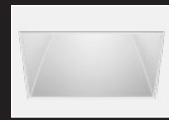

trimless companion

DIMENSIONAL DATA

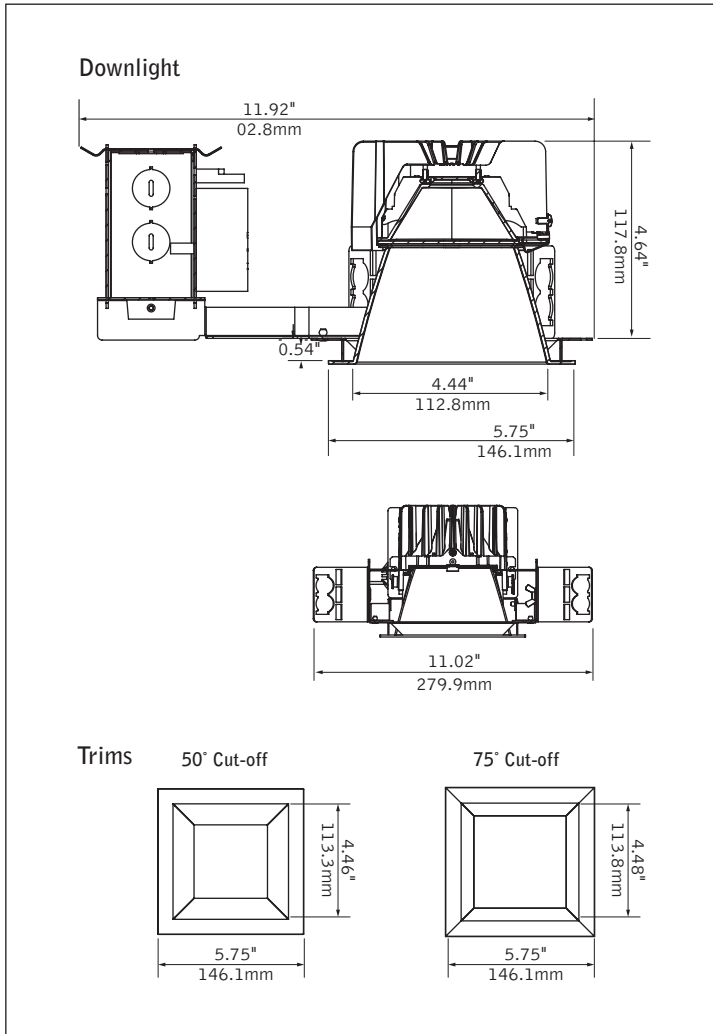

FEATURES

Field adjustability of ceiling thickness from 0.5" to 3.0".

50° or 75° cutoff to light source and its image.

Right Light: Standard delivered lumen outputs 1000, 1500, 2000, 2500, and 3000.

Warm Dim: Lighting that enhances spaces with a warm glow, reminiscent of incandescent or halogen light sources.

PoE compatible: Integrates with Power over Ethernet lighting systems via standard, low-voltage wires.

Compatible with common pre-engineered grid ceiling systems requiring luminaires fitting into a 6" slot.

PERFORMANCE

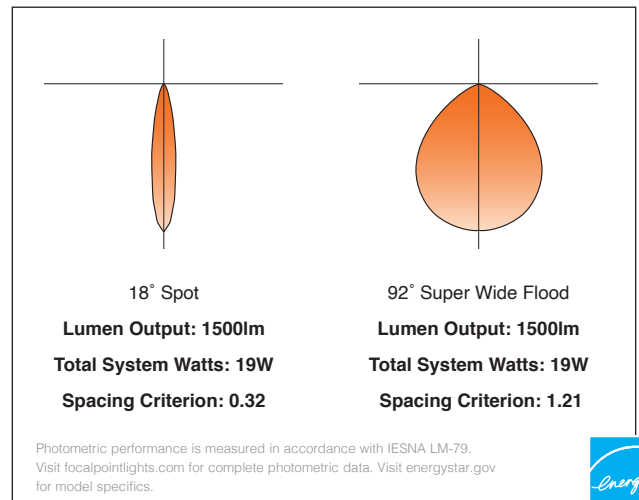

fixture:

project:

HOUSING DETAILS

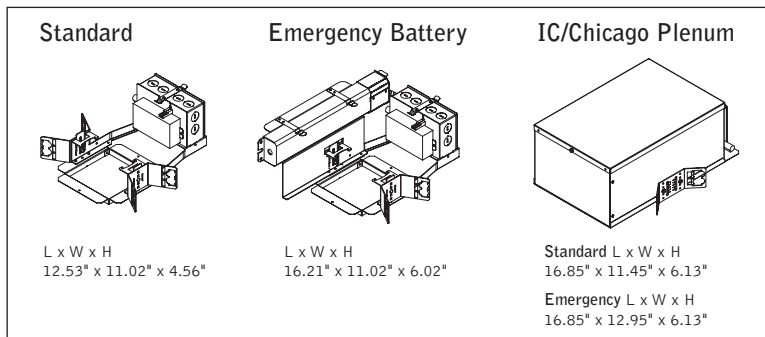

HOUSING SPECIFICATIONS

Construction

Thermally protected housing for new construction applications. Insulation to be kept 3" away from housing. Type IC inherently protected, suitable for direct contact with insulation. Butterfly brackets allow mounting to 1/2" emt. Order bar hangers as an accessory. Die-cast aluminum heat sink designed for maximum thermal dissipation. Die-formed housing and integral junction box with (7) 1/2" pry-outs. T-rated: UL & cUL Listed for (6) #14 AWG (3 in, 3 out) 90°C conductors and feed through-branch wiring. IC/CP housing: UL & cUL Listed for (8) #12 AWG (4 in, 4 out) 90°C conductors and feed through-branch wiring for IC/CP housing. Accommodates ceiling thicknesses up to 0.5" standard, field adjustable up to 3.0" thickness. For thicker ceiling consult factory. Order TZB option for TechZone compatible housing brackets. T-rated housing will not exceed 6lb, IC/CP housing will not exceed 12lb.

Electrical

Choice of constant current dimming drivers. Power factor > .9 typical. PoE compatible: Integrates with Power over Ethernet lighting systems via standard, low-voltage wires.

Emergency

Emergency Battery Pack: Bodine BSL17C-C2. Emergency output —7W for 90 minutes. Maximum mounting height: 25.8ft. (Black reflector: 18.0ft.) Not wet location or outdoor rated.

Labels

UL and cUL Listed. Suitable for Dry, Damp or Wet Locations, indoor use only. Specify Outdoor rated (OD) for outdoor recessed ceiling applications.

Lumen Maintenance

Reported: L70 at >55,000 hours Calculated: L70 at 204,000 hours
 L90 at >55,000 hours L90 at 59,000 hours

Derived from EPA TM-21 calculator. Based on typical conditions, consult factory for additional data.

Reliability

At Focal Point, our products are designed to stand the test of time. Each luminaire is engineered using superior components, manufactured with the utmost care and rigorously tested. Contact us for reliability data.

Warranty

LED System rated for operation in ambient environments up to 25°C. 5-year limited warranty. Fixture with Outdoor rated option must be installed in a covered ceiling and is warranted for operation in ambient environments between -20°C to +40°C.

TRIM & LED SPECIFICATIONS

LED System

Proprietary array incorporates premium LEDs on a robust platform. May be specified in 2700K, 3000K, 3500K or 4000K, 80+ CRI or 90+ CRI. 3500K and 4000K with CRI>90 have a cyanosis observation index (COI) of 3.3 or less. Color accuracy within 2 SDCM. Aluminum heat sink provides appropriate thermal management.

Aesthetics

Torsion springs pull single molded die-cast trim tight to the ceiling with no visible fasteners within the trim.

Optics

50-degree or 75-degree cut-off to light source and its image.

Optic	Cut-Off Degree	Lumen Output	Distribution Beam Spread Spacing Criteria						
			SP	NFL	FL1	FL2	WFL	VWFL	SWFL
DN	50°	1000-2500	18° .32	23° .40	34° .56	45° .72	52° .86	70° 1.08	-
		3000	-	25° .43	39° .64	47° .74	52° .86	70° 1.08	-
DSS	75°	1000-2500	-	-	-	-	-	70° 1.01	92° 1.21
		3000	-	-	-	-	-	70° 1.00	94° 1.22

PERFORMANCE CHART* - see page 3.

Focal Point LLC reserves the right to change specifications for product improvement without notification.



HOUSING ORDERING

Housing Series	FLC44D	FLC44D
ID+ 4.5" Square Downlight	FLC44D	
Trim Type		SO
Square Overlap		SO
Color Options		
Standard White, 80 & 90 CRI	SW	
Warm Dim (1500 & 2000 lumens only. UNV & EM not available.)	WDM	
Lumen Output		
1000 Lumens	1000L	
1500 Lumens	1500L	
2000 Lumens	2000L	
2500 Lumens	2500L	
3000 Lumens	3000L	
(Not available with SP distribution, LFP or LTE.)		
Voltage		
UNV 120V/277V (IC housing only. Not available with LFP or LTE.)	UNV	
120V	120	
277V	277	
Low Voltage (IC housing: 2000L max. T housing: 1000L only.)	LV	
Control System & Dimming Level		
0-10V - 0% Dimming	LZ1	
0-10V - 1% Dimming	L11	
0-10V - 10% Dimming	LD1	
Low Voltage, PoE compatible (No driver. Not available with EM. LV Voltage only.)	LVN	
Forward Phase (120V only)	LFP	
Lutron Hi-Lume EcoSystem (LDE1) - 1% Dimming	LH1	
Lutron 5-Series EcoSystem (LDE5) - 5% Dimming	LU5	
Lutron Hi-Lume - Forward Phase - 1% Dimming (120V only)	LTE	
DALI - 0% Dimming	DZ1	
DALI - 1% Dimming	D11	
Housing Type		
IC Rated / Airtight (L11, LD1, LVN, LH1, LU5 2000L max. LZ1, D11, DZ1, LFP 1500L max. LTE 1000L only. LC44AT required for Airtight. Not available with EM.)	IC	
Thermally Protected	T	
Factory Options		
Bar Hangers	BH	
Chicago Plenum / National Plenum	CP	
Emergency Battery (Must order LC44EM trim. Not wet location or outdoor rated.)	EM	
Outdoor Rated (LD1 driver only. IC housing 1500L max. See dimming Performance Chart on page 3.)	OD	
Bracket for 6" slot pre-engineered ceiling	TZB	
TRIM & LED MODULE		
Aperture		
4.5" Square Reflector	LC44	
4.5" Square Reflector - Airtight (IC housing required for Airtight rating)	LC44AT	
4.5" Square Reflector - Emergency (Required for "EM" option. DN optic only. Not wet location or outdoor rated.)	LC44EM	
Trim Type		SDO
Square Die-Cast Overlap	SDO	
Lumen Output (Trim & Housing output must match)		
1000 Lumens	1000L	
1500 Lumens	1500L	
2000 Lumens	2000L	
2500 Lumens	2500L	
3000 Lumens	3000L	
(Not available with SP distribution)		
Color Temperature		
2700K, 80+ CRI or 90+ CRI	27K or 927K	
3000K, 80+ CRI or 90+ CRI	30K or 930K	
3500K, 80+ CRI or 90+ CRI	35K or 935K	
4000K, 80+ CRI or 90+ CRI	40K or 940K	
Warm Dim: 2700-1800K, 90+ CRI (1500 & 2000 lumens only)	92718W	
Warm Dim: 3000-1800K, 90+ CRI (1500 & 2000 lumens only)	93018W	
Optic		
Downlight with 50° cut-off	DN	
Super Short Cone with Solite Lens 75° cut-off (VWFL or SWFL only)	DSS	
Distribution		
Spot	SP	
Narrow Flood	NFL	
Flood 1	FL1	
Flood 2	FL2	
Wide Flood	WFL	
Very Wide Flood	VWFL	
Super Wide Flood (DSS Optic only)	SWFL	
Color		
Clear Diffuse	CD	
Warm Diffuse	WD	
Black (Black Flange Finish only)	BK	
White (White Flange Finish only)	WH	
Flange Finish		
Non-Painted (Clear and warm diffuse only)	NP	
Black Painted	BP	
White Painted	WP	



Options in orange qualify for the Quickship program. 5-day up to 200 pieces. Refer to Quickship Guide for complete details.

SQUARE DOWNLIGHT PERFORMANCE CHART

Lumen Output	Delivered Lumens	System Watts	LPW
1000L	1016	11	89
1500L	1527	19	80
 1500L	1480	25	58
2000L	2028	26	79
 2000L	2079	37	57
2500L	2452	32	76
3000L	2941	36	81

Based on downlight (DN) optic, 3500K, 80CRI, Wide Flood, Clear Diffuse.
Delivered lumen output may vary +/- 5%. Actual wattage may vary +/- 5%

OUTDOOR RATED (OD) DRIVER DIMMING PERFORMANCE CHART

Lumen Output	Minimum Dimming Level
1000L	25%
1500L	16%
2000L	12%
2500L	10%
3000L	10%

SQUARE DOWNLIGHT LUMEN MULTIPLIER TABLE

Color Temperature & CRI

Trim Type	Optic	Color Temperature	Multiplier	
ALL	ALL	2700K, 80+ CRI [27K]	0.93	
		2700K, 90+ CRI [927K]	0.75	
		3000K, 80+ CRI [30K]	0.93	
		3000K, 90+ CRI [930K]	0.81	
		3500K, 80+ CRI [35K]	1.00	
		3500K, 90+ CRI [935K]	0.81	
		4000K, 80+ CRI [40K]	1.00	
		4000K, 90+ CRI [940K]	0.87	
		1500	2700-1800K, 90+ CRI [92718W]	0.93
		2000		1.09
		1500	3000-1800K, 90+ CRI [93018W]	0.99
		2000		1.04

Distribution

Trim Type	Optic	Distribution	Multiplier	
			1000 - 2500L	3000L
Square Die-Cast Trimless [SDT]	Downlight with 50° cut-off [DN]	Spot [SP]	1.05	-
		Narrow Flood [NFL]	1.04	1.04
		Flood 1 [FL1]	0.97	0.96
		Flood 2 [FL2]	0.99	0.98
		Wide Flood [WFL]	1.00	1.00
		Very Wide Flood [VWFL]	0.94	0.93
Square Die-Cast Overlap [SDO]	Downlight with 50° cut-off [DN]	Spot [SP]	1.03	-
		Narrow Flood [NFL]	1.02	1.02
		Flood 1 [FL1]	0.96	0.93
		Flood 2 [FL2]	0.97	0.94
		Wide Flood [WFL]	0.98	0.98
Square Die-Cast Trimless [SDT]	Super Short Cone with Solite Lens with 75° cut-off [DSS]	Very Wide Flood [VWFL]	0.87	0.88
		Super Wide Flood [SWFL]	0.81	0.84
Square Die-Cast Overlap [SDO]	Super Short Cone with Solite Lens with 75° cut-off [DSS]	Very Wide Flood [VWFL]	0.80	0.82
		Super Wide Flood [SWFL]	0.81	0.75

Color

Trim Type	Optic	Color	Multiplier
Square Die-Cast Trimless [SDT] and Square Die-Cast Overlap [SDO]	Downlight with 50° cut-off [DN]	Clear Diffuse [CD]	1.00
		Warm Diffuse [WD]	0.84
		White [WH]	1.11
		Black [BK]	0.65
	Super Short Cone with Solite Lens with 75° cut-off [DSS]	Clear Diffuse [CD]	1.00
		Warm Diffuse [WD]	1.01
		White [WH]	1.16
		Black [BK]	0.93

Multiplier charts are provided to aid with estimation of lumen levels across options. Apply multipliers against ordered Lumen Output to estimate Delivered Lumens. An estimation should make use of all tables through consecutive application of three multipliers. Refer to IES files for most accurate photometric information

How To Use Lumen Multipliers

Formula: (Lumen Output Value) x (Color Temperature & CRI) x (Distribution) x (Color)

Example: LC44-SDO-2000L-935K-DN-NFL-WH

(2000) x (0.81) x (1.02) x (1.11) ≈ 1834 lm (estimated delivered lumens)