

# seem 6™ led mud-in drywall

FSM6L -XF



**! LUMINAIRE MUST BE INSTALLED PRIOR TO DRYWALL. !**

**! CONFIGURATIONS ARE RUN SPECIFIC, PLEASE CONSULT FACTORY DRAWINGS BEFORE BEGINNING INSTALLATION. !**

**FOCAL POINT**

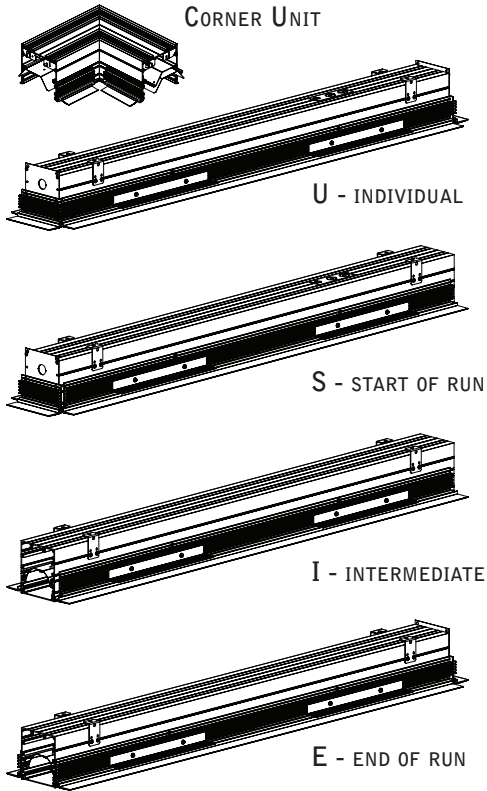

**PARTS LISTS**

**INCLUDED HARDWARE**

REFLECTOR SCREW (72010)	JOINER BULKHEAD SCREW (72010)
LENS TOOL (A15966-01) (AFFIXED TO HOUSING. ONE PER RUN)	MUD FLANGE (70005) (8-32 X 5/16" FLAT UNDERCUT HEAD SCREW)
BACKER FLANGE (72001) (8-32X 3/8" WASHER HEX HEAD SCREW)	

**SHIPPED INSTALLED**

JOINER BRACKET SCREW (72009)	JOINER BRACKET (A15328-01)	LENS END PIECE (A12498)
TIE-WIRE BRACKET SCREW (72010) (8-18 x 1/4 SELF TAPPING SCREW)	TIE-WIRE BRACKET (12547)	JOINER BULKHEAD (A15570-01)

**KEY**

- POWER OFF
- POWER ON
- ATTENTION

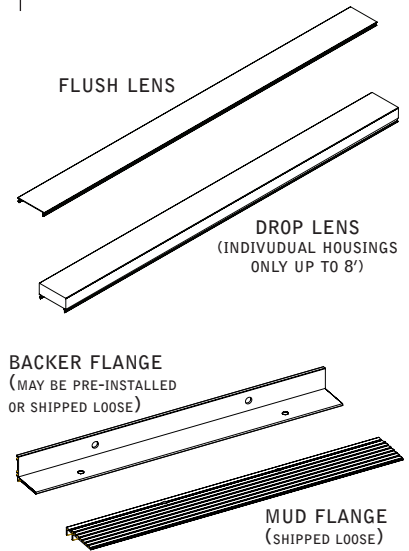

**BACKER FLANGE PLACEMENT GUIDE**

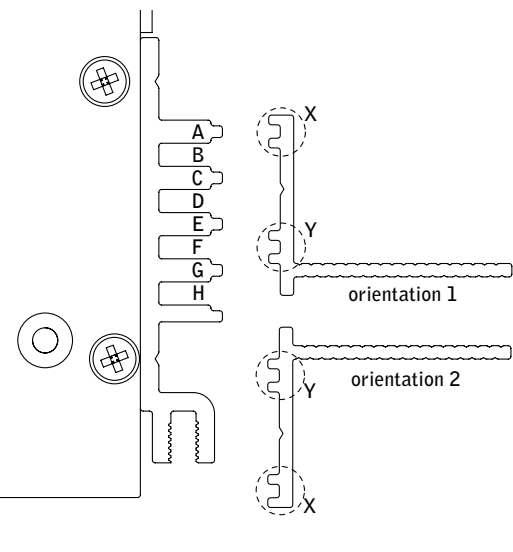

DRYWALL THICKNESS	ORIENTATION	GUIDE POINT	POSITION
3/8"	1	X	F
1/2"	1	X	E
5/8"	1	X	D
3/4"	1	X	C
7/8"	1	X	B
1"	1	X	A
1 1/8"	1	Y	G
1 1/4"	2	Y	F
1 3/8"	2	Y	E
1 1/2"	2	Y	D
1 5/8"	2	Y	C
1 3/4"	2	Y	B
1 7/8"	2	Y	A
2"	2	X	E
2 1/8"	2	X	D

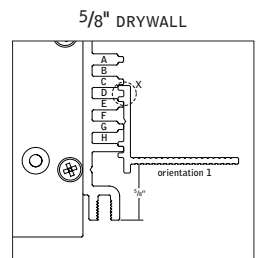
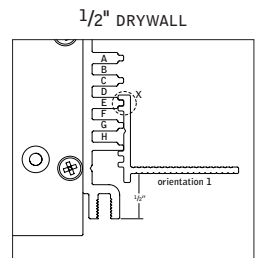

Luminaires must be installed by a qualified electrician (check with local and national codes for proper installation).  
To prevent electrical shock, disconnect electrical supply before installation or servicing.

# CEILING INSTALLATION (SEE PAGE 4 FOR WALL INSTALLATION)

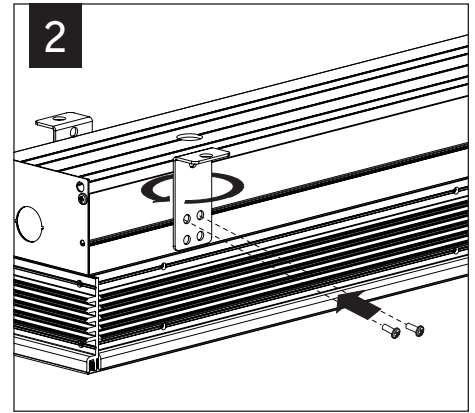
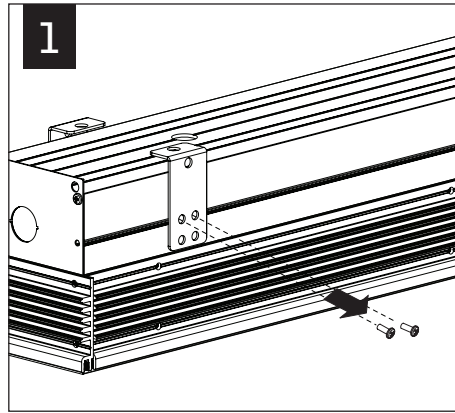
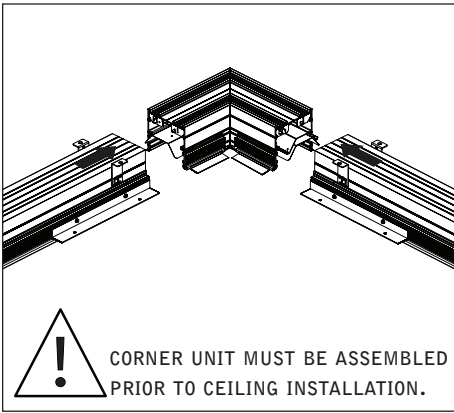

**3** USING THE BACKER FLANGE PLACEMENT GUIDE FROM PAGE 1 DETERMINE THE PROPER PLACEMENT OF THE BACKER FLANGE FOR YOUR DRYWALL THICKNESS.

IF BACKER FLANGES WERE PRE-INSTALLED SKIP TO STEP 5

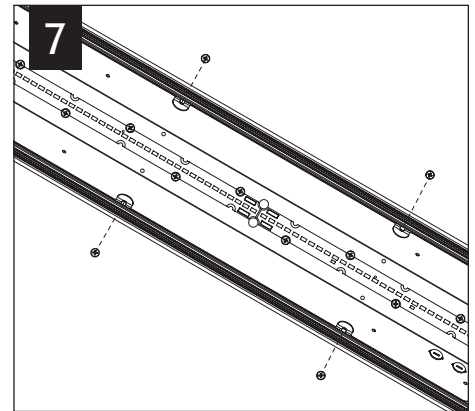
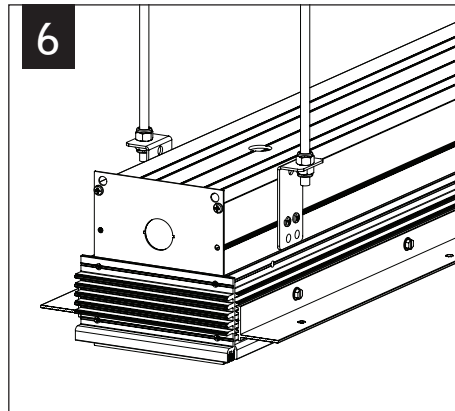
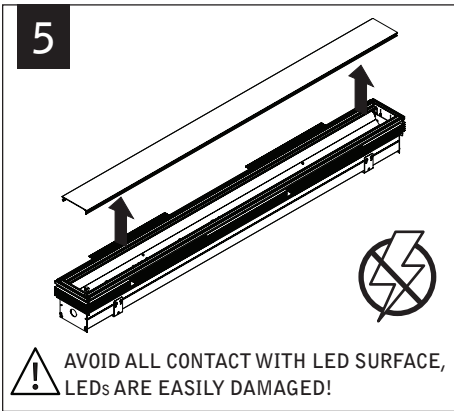
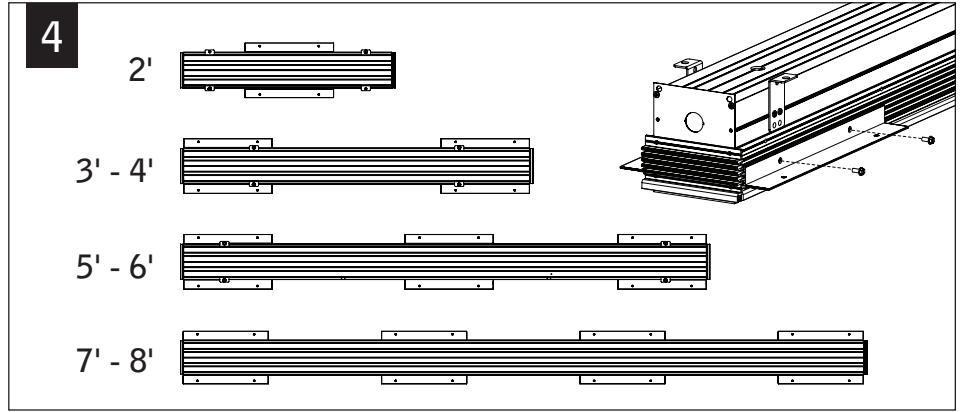

INDIVIDUAL INSTALLATIONS SKIP TO STEP 12

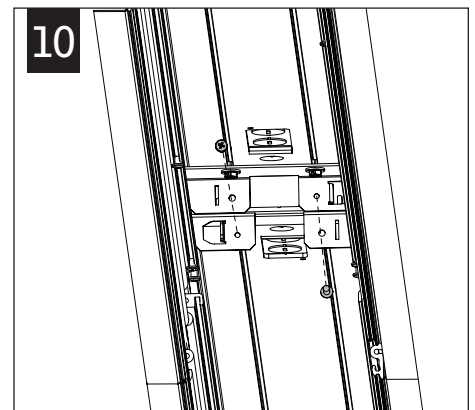
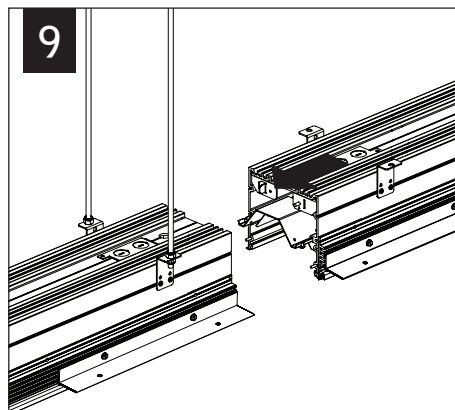
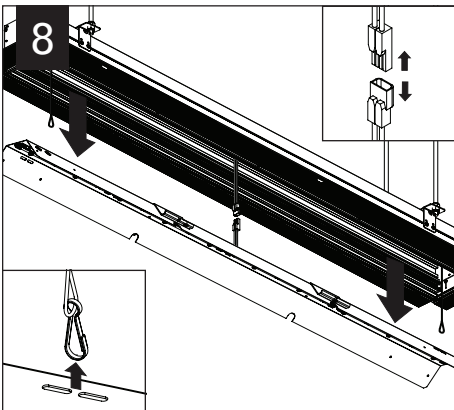

Luminaires must be installed by a qualified electrician (check with local and national codes for proper installation). To prevent electrical shock, disconnect electrical supply before installation or servicing.

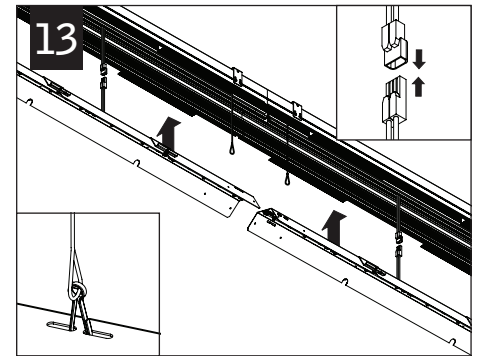
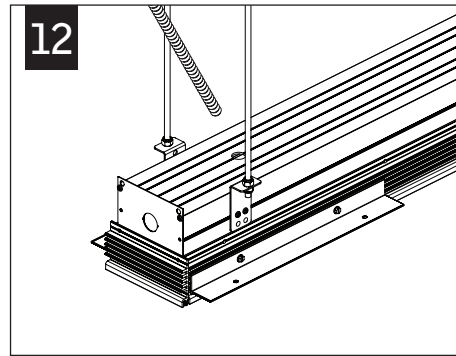
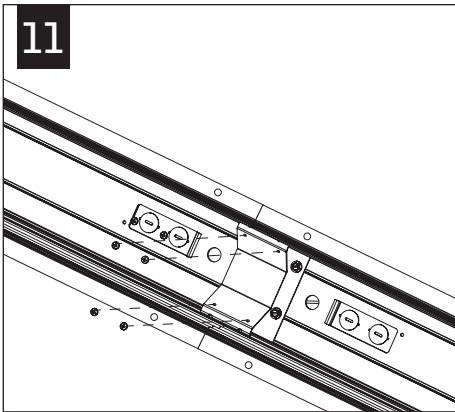

**MAKE ELECTRICAL CONNECTIONS**

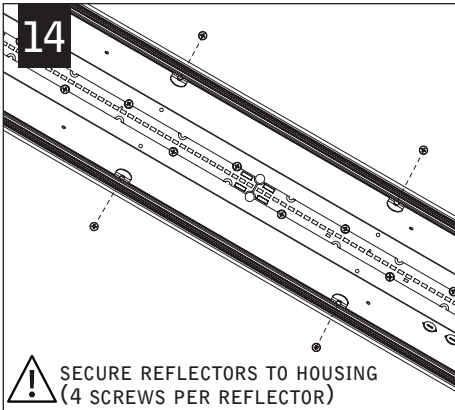

**15**

**ATTENTION**

BEFORE BEGINNING DRYWALL INSTALLATION CONSULT GUIDE ON PAGE 1 TO ENSURE THE BACKER FLANGE IS SET AT THE CORRECT DEPTH FOR THE DRYWALL.

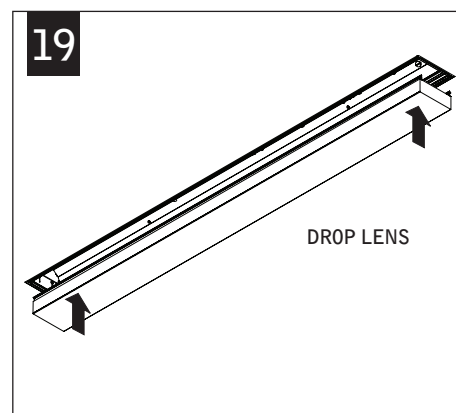
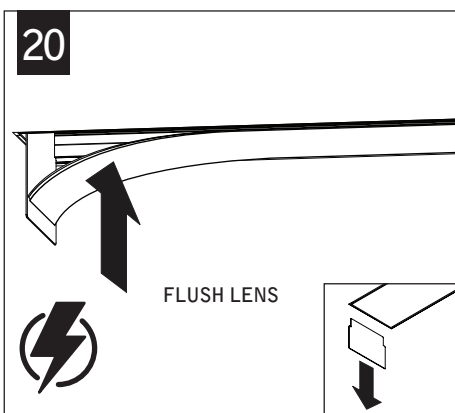
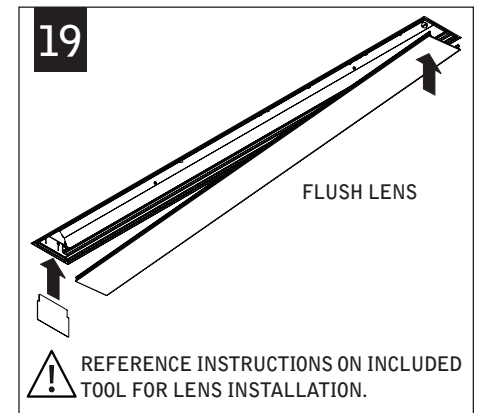
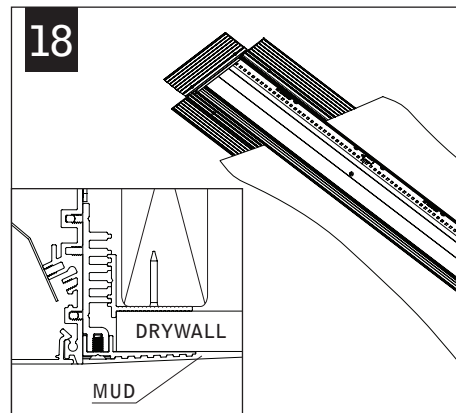
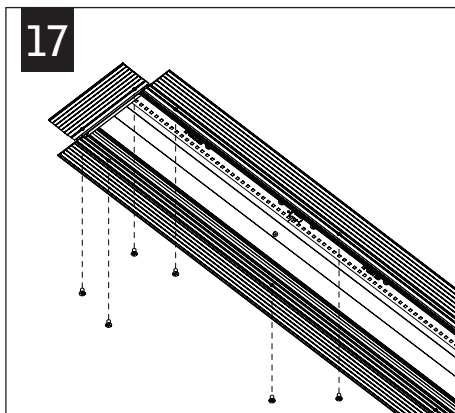
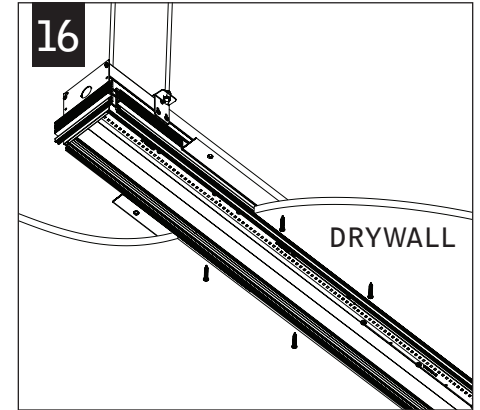

Luminaires must be installed by a qualified electrician (check with local and national codes for proper installation).  
To prevent electrical shock, disconnect electrical supply before installation or servicing.

# WALL INSTALLATION

## 1 2"x6" FRAMING REQUIRED ON BOTH SIDES OF OF HOUSING



trimless mud-in

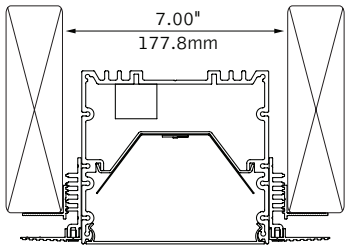

hard surface

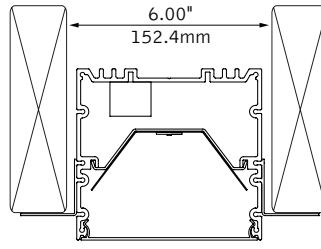

**3** USING THE BACKER FLANGE PLACEMENT GUIDE FROM **PAGE 1** DETERMINE THE PROPER PLACEMENT OF THE BACKER FLANGE FOR YOUR DRYWALL THICKNESS.

IF BACKER FLANGES WERE PRE-INSTALLED SKIP TO STEP 4

**3**

2'



3' - 4'



5' - 6'



7' - 8'

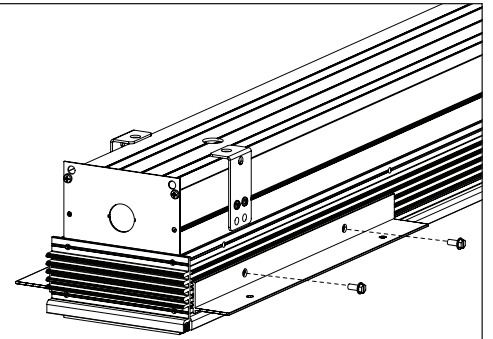

**4**

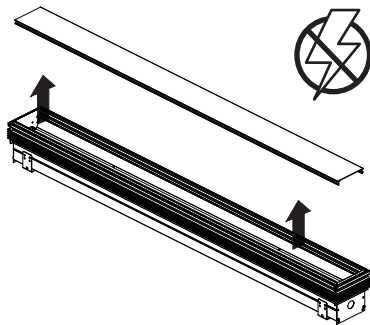

**!** AVOID ALL CONTACT WITH LED SURFACE, LEDs ARE EASILY DAMAGED!

**5**

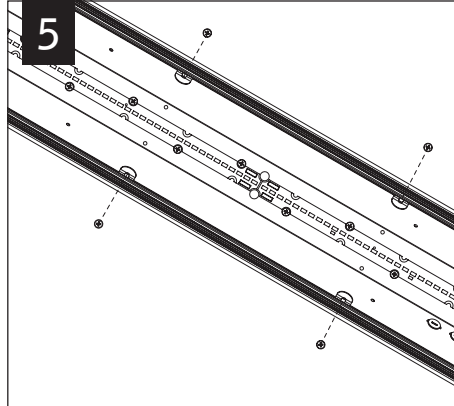

**6**

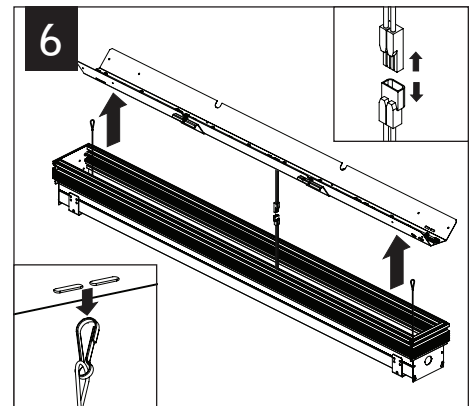

**7**

x4

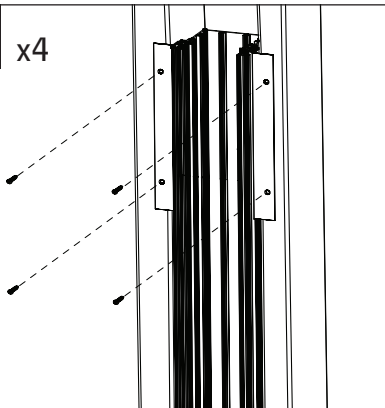

INDIVIDUAL INSTALLATIONS SKIP TO STEP 11

**8**

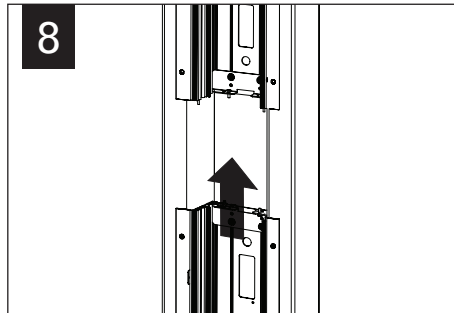

**9**

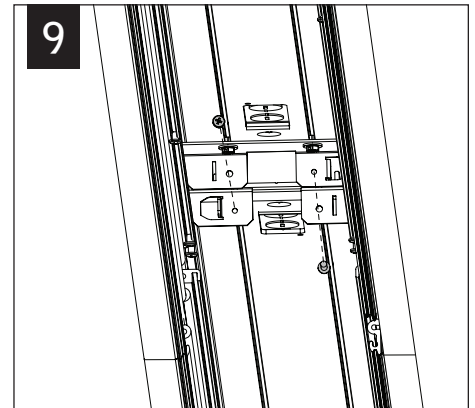

Luminaires must be installed by a qualified electrician (check with local and national codes for proper installation).  
To prevent electrical shock, disconnect electrical supply before installation or servicing.

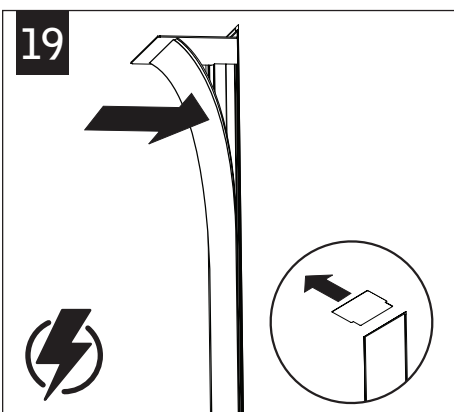
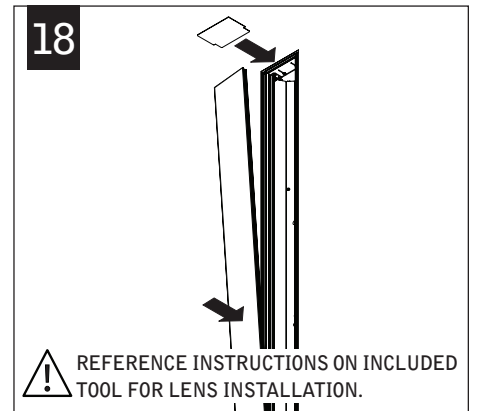
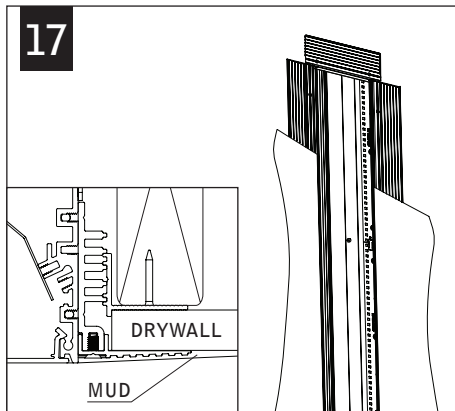
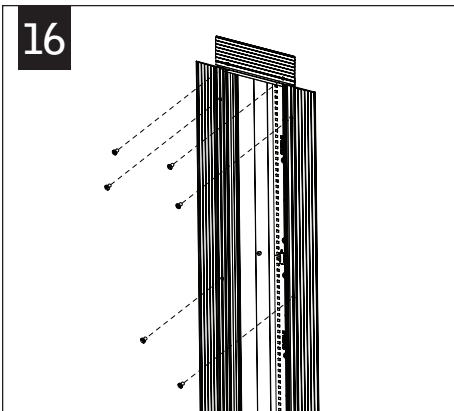
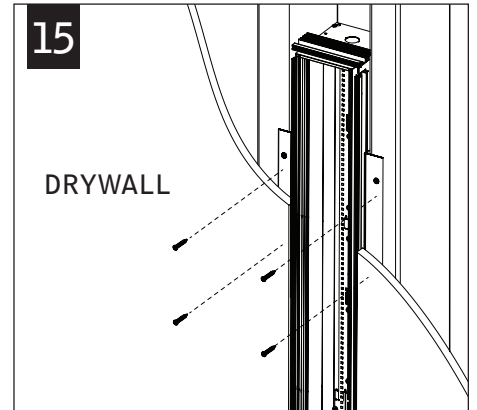
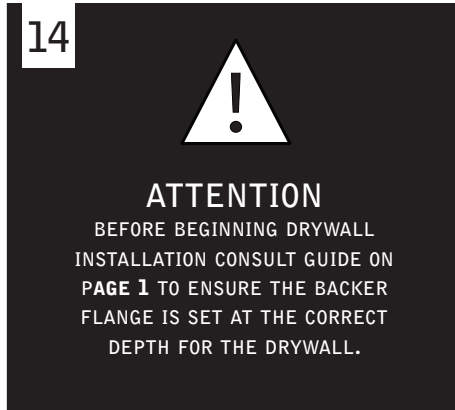
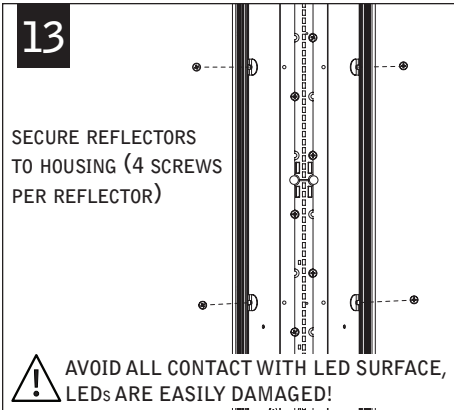
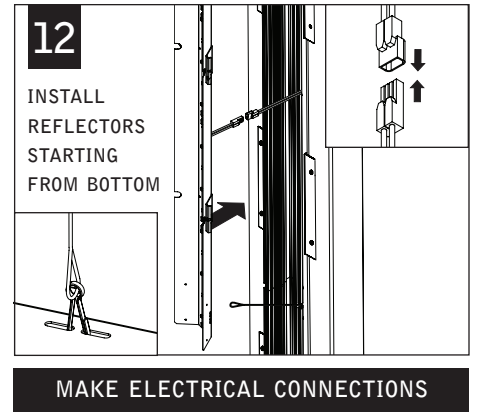
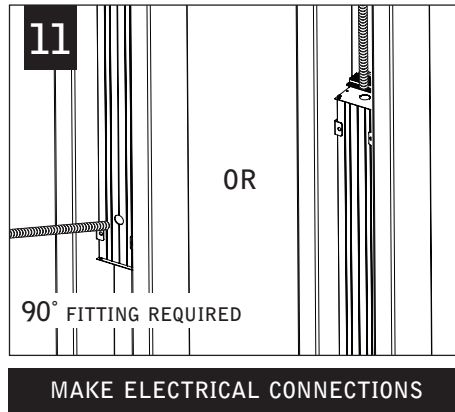
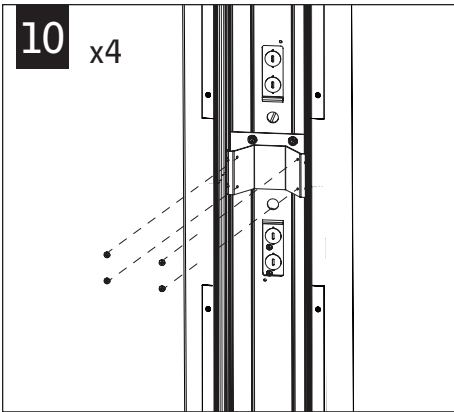

Luminaires must be installed by a qualified electrician (check with local and national codes for proper installation).  
To prevent electrical shock, disconnect electrical supply before installation or servicing.

## DRIVER SERVICE

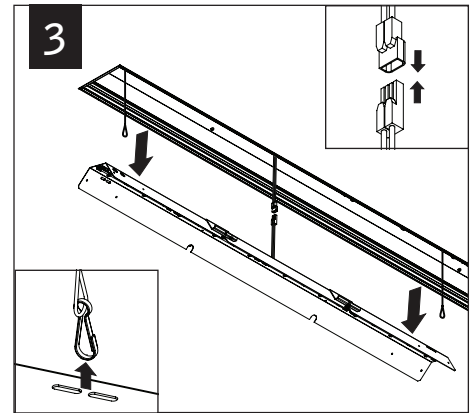
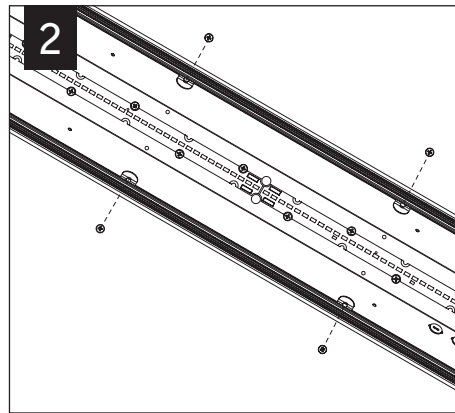
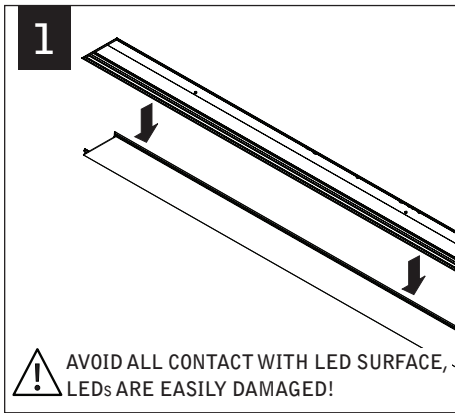

## EMERGENCY



### SEE BATTERY MANUFACTURER INSTRUCTIONS

EMERGENCY BATTERY  
MAXIMUM MOUNTING HEIGHT: 18.00'

EMERGENCY CIRCUIT  
MAXIMUM MOUNTING HEIGHT: 21.00'