

# Ori<sup>®</sup> Acoustic Tile

AUO

AirCore<sup>®</sup> Technology



FOCAL POINT<sup>®</sup>

## BEFORE YOU BEGIN

- Contractor is responsible for adequately reinforcing walls and/or ceilings to support fixture weight.
- Focal Point, LLC accepts no responsibility for inadequately reinforced walls and/or ceilings.
- The information contained in this drawing is the sole property of Focal Point, LLC. Any reproduction in part or whole without the written permission of Focal Point, LLC is prohibited.

## INSTRUCTION KEY



## COMPONENT KEY

### FOCAL POINT

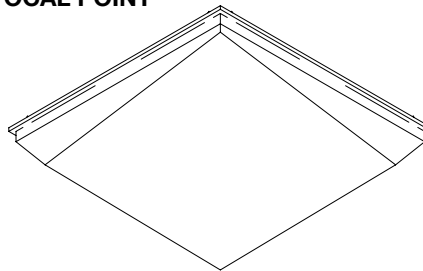

Standard Assembly

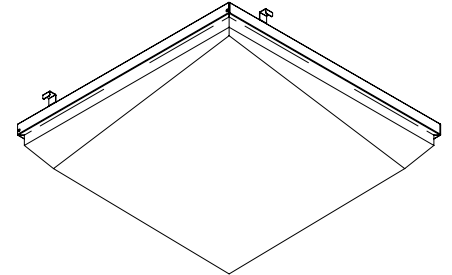

Plenum/Chicago Plenum Assembly

## PROFILE KEY

### SIMPLE SLOPE 1 (SS1)

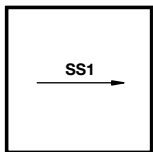
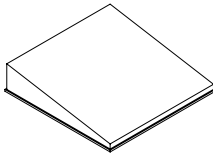

### SIMPLE SLOPE 2 (SS2)

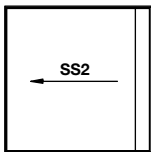
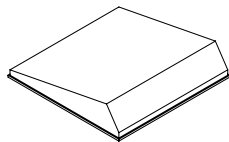

### DYNAMIC SLOPE 1 (DS1)

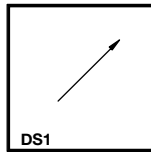
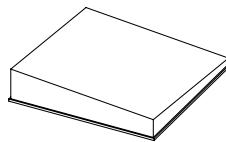

### DYNAMIC SLOPE 2 (DS2)

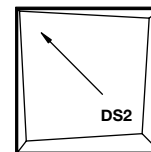
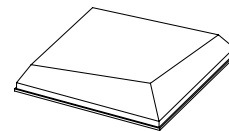

### VALLEY 1 (VY1)

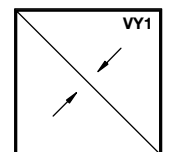
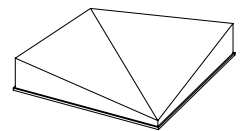

### VALLEY 2 (VY2)

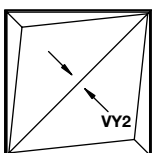
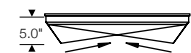
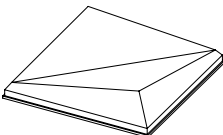

### PLATEAU 1 (PT1)

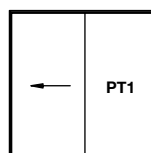
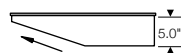
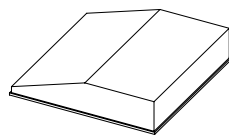

### PLATEAU 2 (PT2)

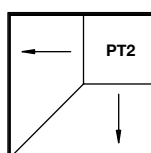
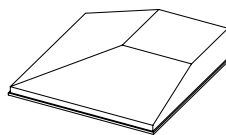

### PEAK 1 (PK1)

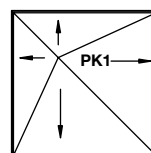
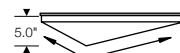
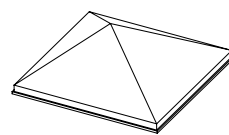

### PLAIN (PLN)

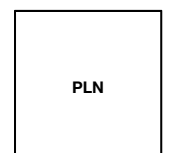
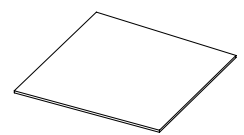



**ORI ACOUSTIC TILE**  
**DO NOT** apply any weight on or suspend objects from tile.



## STANDARD INSTALLATION

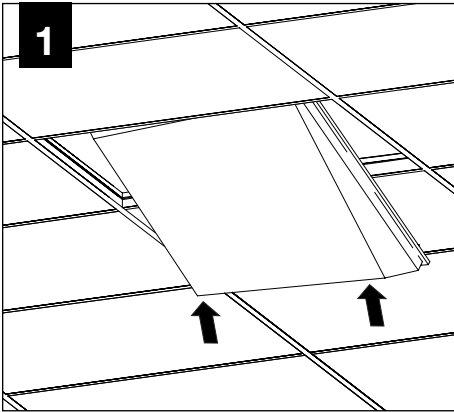

### ORI ACOUSTIC TILE - PLAIN AUO-22-PLN

To integrate with sprinkler heads, downlights or other ceiling objects, it is recommended to **only cut PLAIN (PLN) acoustic tiles**, using a utility knife with fresh blade and a steady hand.

**DO NOT** apply any weight on or suspend objects from tile.

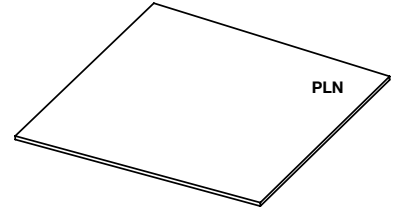

**UTILITY KNIFE WITH  
 FRESH BLADE**



**STEADY HAND**

## PLENUM/CHICAGO PLENUM INSTALLATION

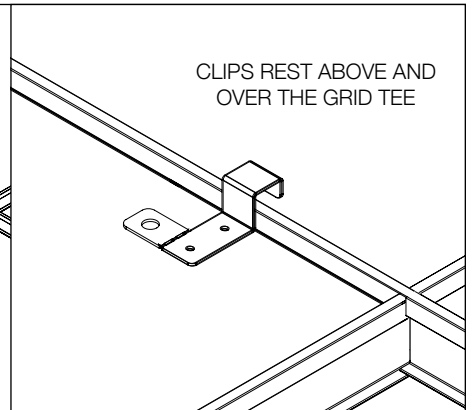
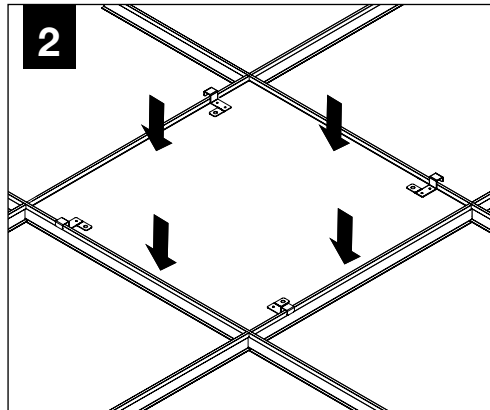
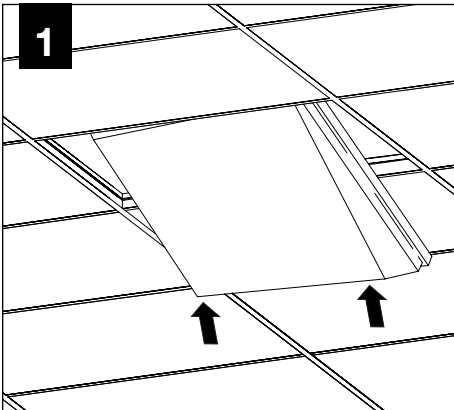

### SECURE TO STRUCTURE ABOVE [OPTIONAL]

