



Nivo[®]

INTEGRATED TROFFER AND ACOUSTIC TILE SYSTEM



FOCAL POINT[™]

Bringing It All To Light[™]

Nivo®

A 2x2 tile with surprising dimension, Nivo invites creativity and imparts a bold statement into any space. Whether flush with the ceiling or extended into the room, Nivo takes the ceiling plane to the next level.

With illumination and sound management, Nivo delivers more comfortable environments with flexibility.



EXPLORE THE DESIGN POSSIBILITIES

Paired together, Nivo luminaires and acoustic tiles create a ceiling system that displays a glowing elegance and helps control noise levels and reverberation issues in various environments.

Combine different depths or create patterns with placement; Nivo gives you the tool to express your creativity and add dimension to the ceiling plane. The flexible system can be customized to meet the needs of each project, allowing specifiers to achieve the desired illumination and acoustic reverberation levels with a coordinated look.



5x5 DIAMOND

(8) 7" drop luminaires

(5) 2" drop acoustic tiles

(12) 4" drop acoustic tiles

| | | | | |
|---|---|---|---|---|
| 2 | 4 | 7 | 4 | 2 |
| 4 | 7 | 4 | 7 | 4 |
| 7 | 4 | 2 | 4 | 7 |
| 4 | 7 | 4 | 7 | 4 |
| 2 | 4 | 7 | 4 | 2 |



3x5 RIDGE

- (5) 7" drop luminaires
- (6) 3" drop acoustic tiles
- (8) 5" drop acoustic tiles

| | | | | |
|---|---|---|---|---|
| 7 | 5 | 3 | | |
| 5 | 7 | 5 | 3 | |
| 3 | 5 | 7 | 5 | 3 |
| | 3 | 5 | 7 | 5 |
| | | 3 | 5 | 7 |



3x5 CHECKER

- (7) 4" drop luminaires
- (8) 2" drop acoustic tiles

| | | | | |
|---|---|---|---|---|
| 2 | 4 | 2 | 4 | 2 |
| 4 | 2 | 4 | 2 | 4 |
| 2 | 4 | 2 | 4 | 2 |

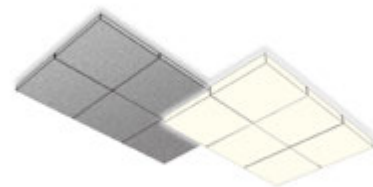

2x3 OVERLAP

- (6) 4" drop luminaires
- (5) 2" drop acoustic tiles

| | | | | |
|---|---|---|---|---|
| | | 4 | 4 | 4 |
| 2 | 2 | 4 | 4 | 4 |
| 2 | 2 | 2 | | |

Nivo[®] LUMINAIRE



- 2x2 Solid or Hollow diffuser options
- Various drop heights from flush to 7" down from the ceiling plane in 1" increments
- Up to 4000 lumens
- Up to 92 LPW
- Driver options: 0-10V and Lutron EcoSystem[®]
- Designed for 9/16" and 15/16" T grid
- Plenum options available
- Use as individual units or cluster to add dimension to the ceiling plane

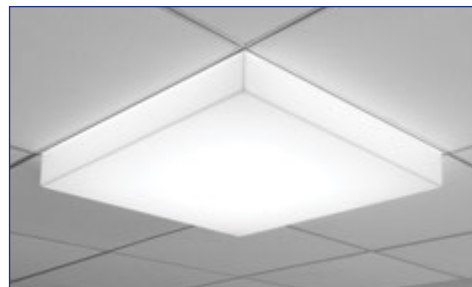

3" DROP SOLID DIFFUSER



3" DROP HOLLOW DIFFUSER

PERFORMANCE

Square LED panels evenly illuminate the frosted acrylic lens to create a soft and pleasant glow. LEDs are spaced to maximize the beauty of the lens and deliver up to 92 LPW.

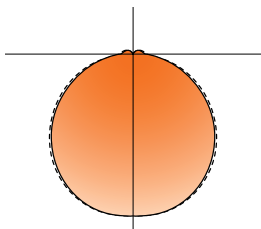

2" DROP

| | |
|---------------------|--------|
| Delivered Lumens: | 2000lm |
| Total System Watts: | 24W |
| LPW: | 83 |

EASE OF MAINTENANCE

The diffuser is held in the housing with simple but robust springs and secured with lanyards for safety while a one-piece hinging optical assembly allows for easy access to LED boards and drivers.



BELOW CEILING ACCESS

FLUSH TO 7" DROP SOLID DIFFUSER

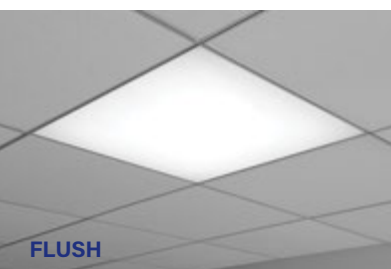

FLUSH

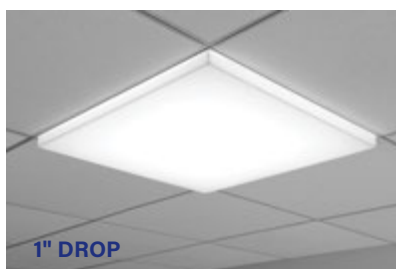

1" DROP

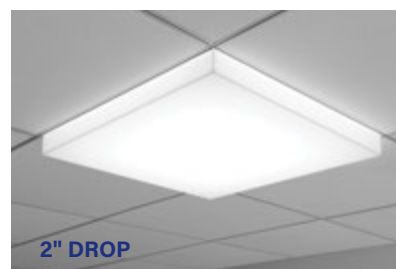

2" DROP

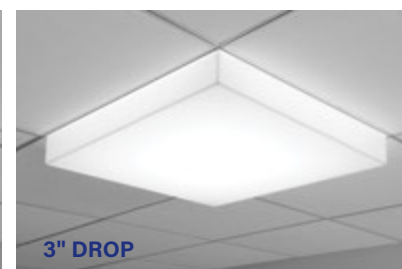

3" DROP

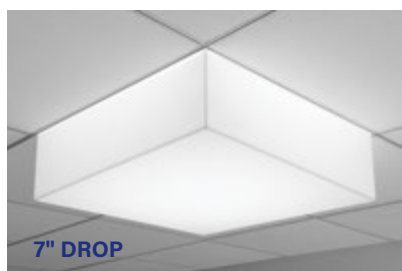

Nivo® ACOUSTIC

- Sound absorbing ceiling tile companion to the Nivo luminaire
- Standard 2x2 tile format; other dimensions available as custom upon request
- Various drop heights from flush to 7" down from the ceiling plane in 1" increments
- Designed for 9/16" and 15/16" T grid or a suspended ceiling cloud
- Plenum option meets construction requirements for CCEA (Chicago Plenum) marking, 2015 IBC 602.2 & 2018 NFPA 90A
- AirCore® Technology: patent pending, eco-friendly technology that maximizes sound absorption and reduces ecological impact, resulting in better sound absorption properties than standard Acoustical Ceiling Tiles (ACT)
- Folded tile design results in crisp corners relative to thermoformed tiles

ACOUSTIC MATERIAL PROPERTIES

- A broad color palette, ranging from neutral to bold, provides design flexibility and personalization for any project
- Material is 100% polyester containing up to 50% of recycled plastic bottles (PET)
- Declare Certified, LBC Red List Free
- 9mm thickness
- ASTM E-84 Class A / CAN ULC S102 fire rating and moisture resistant

Acoustic material colors are subject to change without notice, refer to focalpointlights.com for current palettes.

ACOUSTIC PERFORMANCE

The Noise Reduction Coefficient (NRC) ranges from 0.9 to 1.3 depending on the tile drop height. Refer to ASTM C423 test reports for more information.

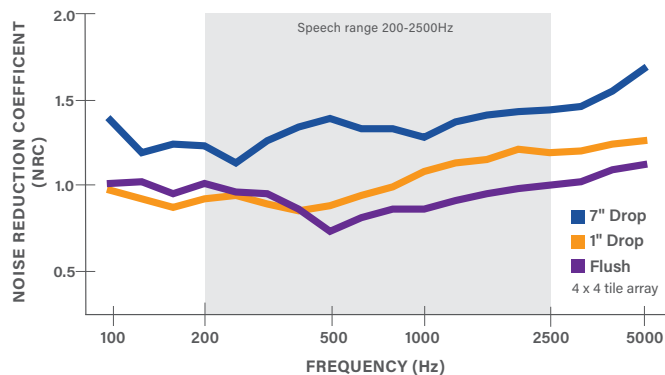

*Standard tile only. Plenum results will vary.

NRC is the average of how absorptive a material is at various frequencies within the human speech frequency range. Two materials with the same rating may not perform the same in application. Typically, an NRC of 0 indicates perfect reflection and an NRC of 1 is designated as perfect absorption. However, based on the testing methodology and depending upon the material's shape or surface area, products can test at an NRC greater than 1.

EASE OF INSTALLATION

Sound absorbing tiles engineered to reduce shipping costs with flat packing and easy toolless assembly in the field with a simple four-step process.

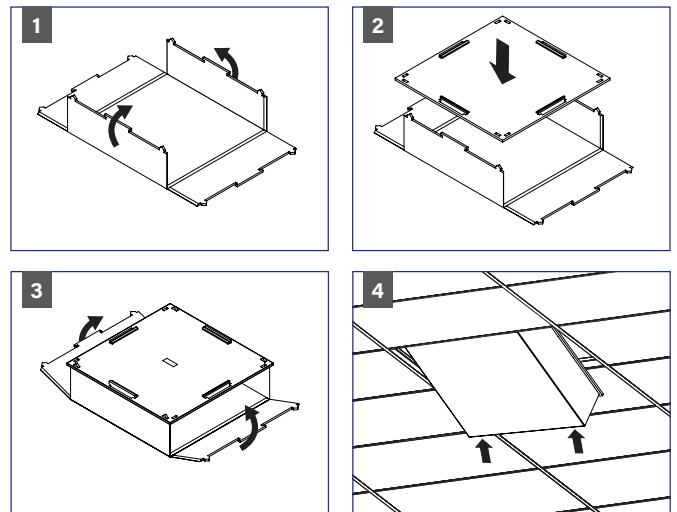

FLUSH TO 7" DROP ACOUSTIC CEILING TILE

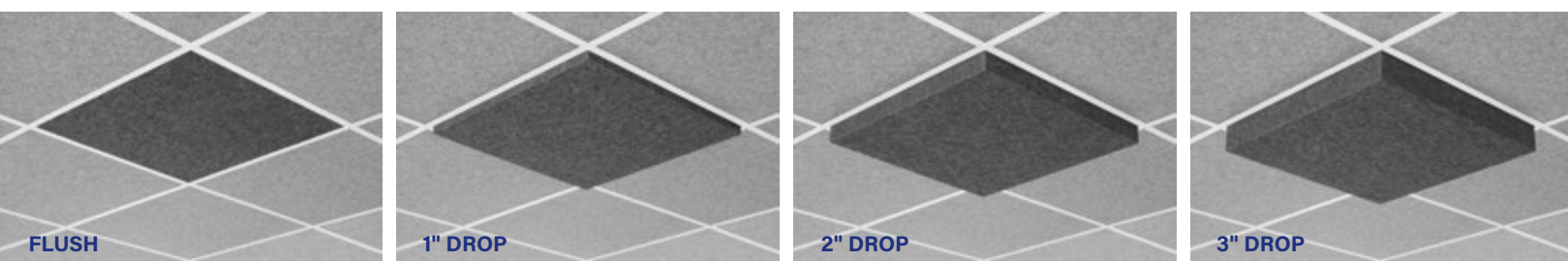

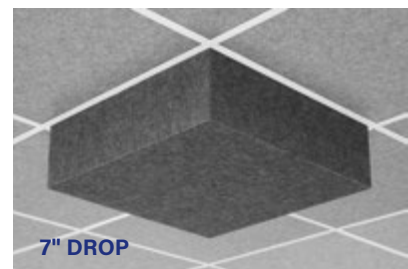
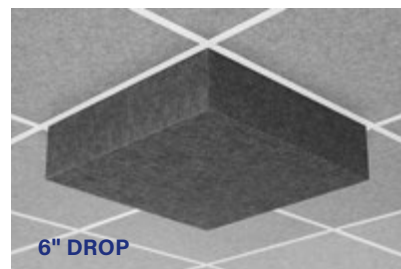
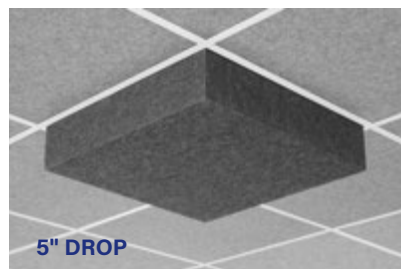
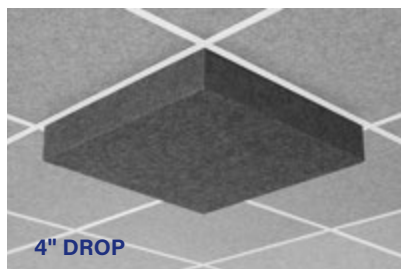

SUPPORTS GLOBAL BUILDING STANDARDS

- Helps achieve **WELL Building Standard™**: Supports the achievement of WELL v1 Features 78 and 80 and WELL v2 Feature S04.
- Helps achieve **LEED v4.1**: Supports meeting the recommended reverberation times, contributing to the achievement of Acoustic Performance prerequisites and credits of LEED v4.1 BD+C and ID+C.

Photometric files and acoustic calculations can be provided to help optimize your space.

For more information on how to specify acoustic systems, or for general inquiries regarding the Focal Point Acoustic Solutions offering, please email acoustic.solutions@focalpointlights.com or contact your Focal Point representative.



FOCAL POINT®

Bringing It All To Light®

