

verve™ IV - wall mount

FV4W



FOCAL POINT®

FOCAL POINT

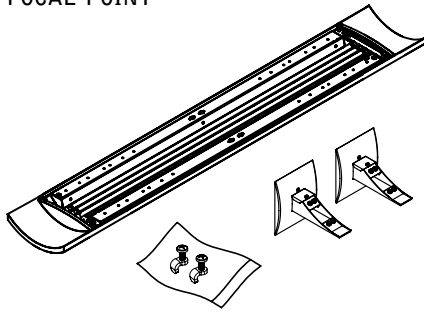

OPTIONAL DUST COVER
8.25" W (+/- .10")

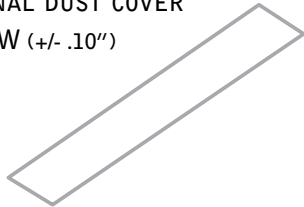

UNIT DESCRIPTION

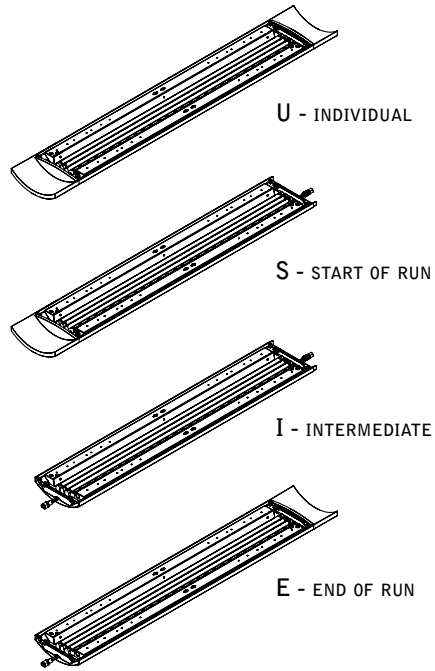

KEY



POWER OFF

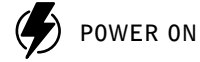

POWER ON



ATTENTION

LUMINAIRE WEIGHTS

4' - 20LBS

8' - 30LBS



KEEP LUMINAIRE IN ORIGINAL
CARTON UNTIL READY TO INSTALL.
DO NOT REST ON THE GROUND.

MOUNTING LOCATIONS

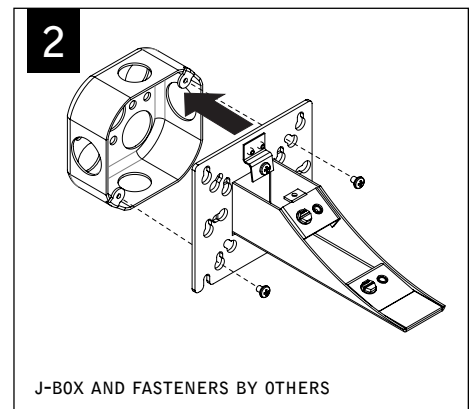
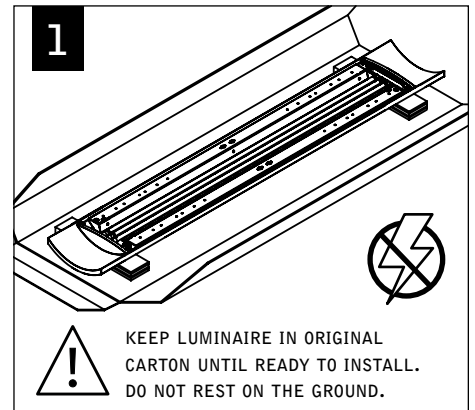
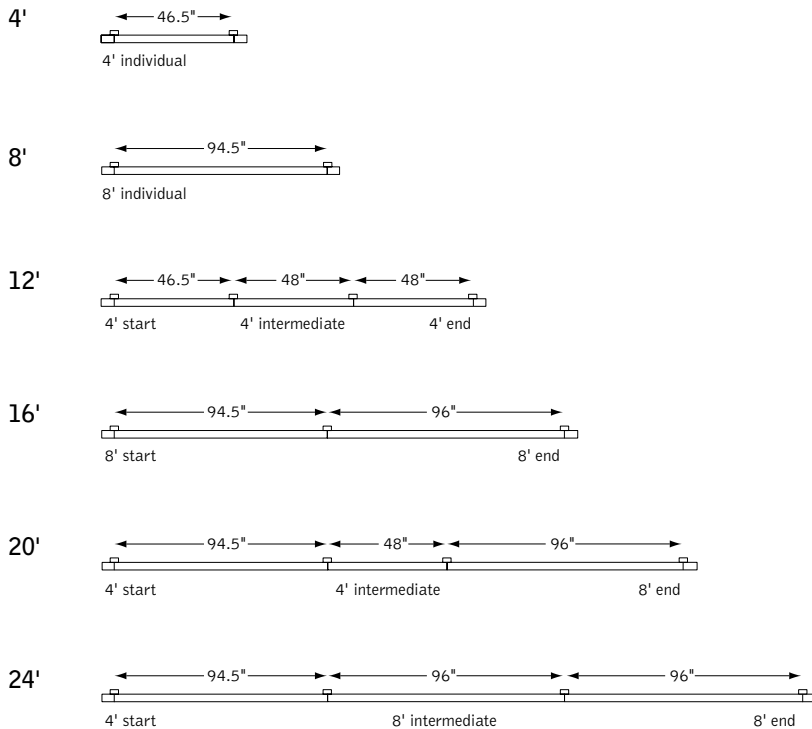

Luminaires must be installed by a qualified electrician (check with local and national codes for proper installation).
To prevent electrical shock, disconnect electrical supply before installation or servicing.

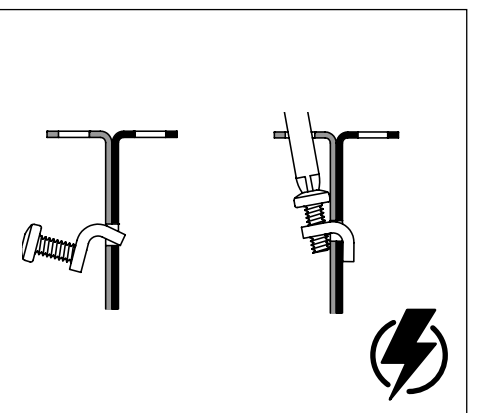
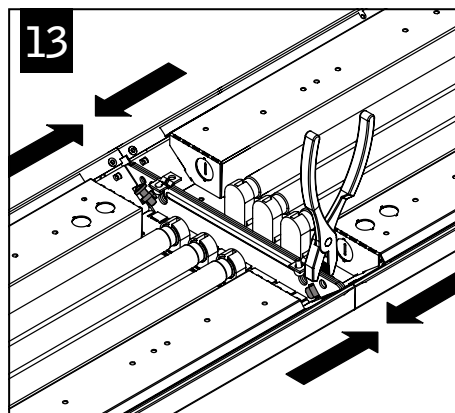
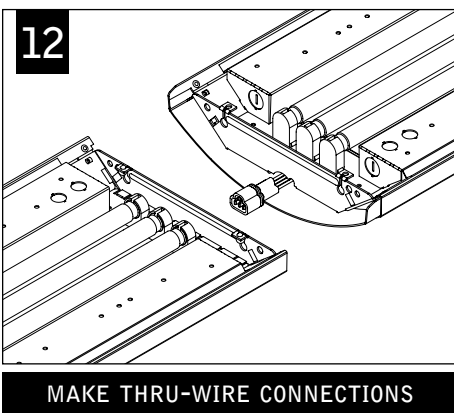
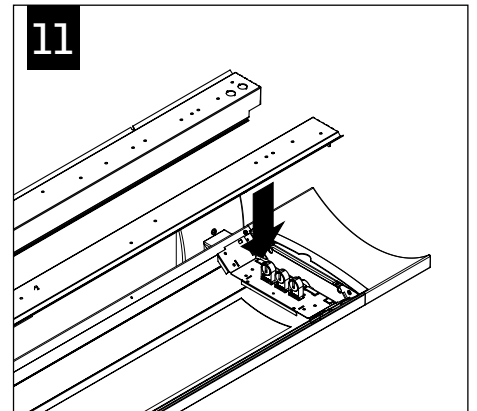
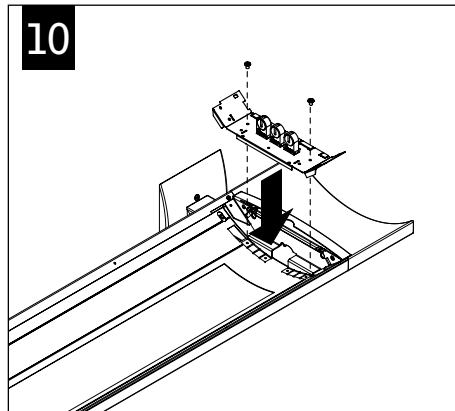
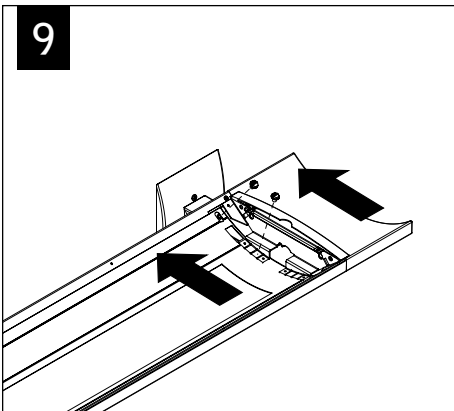
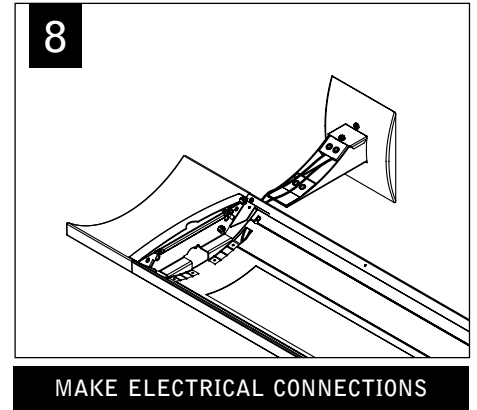
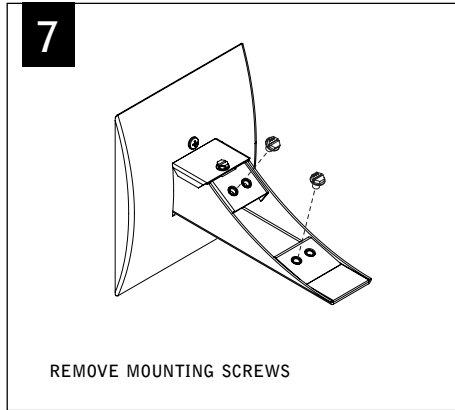
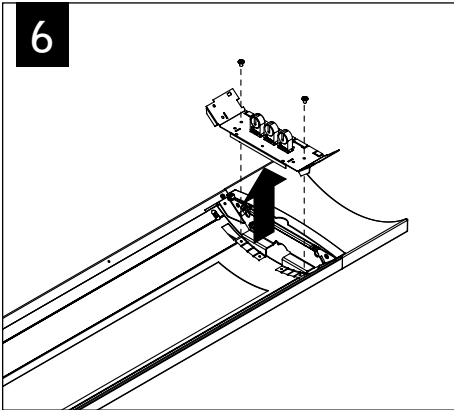
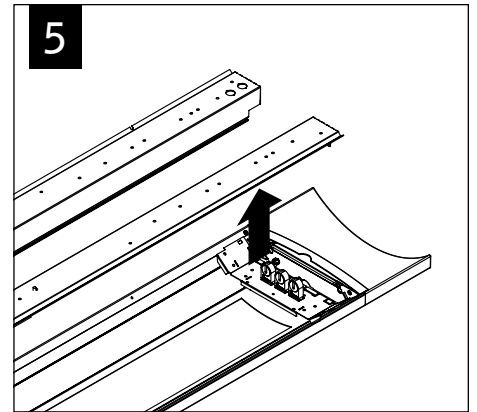
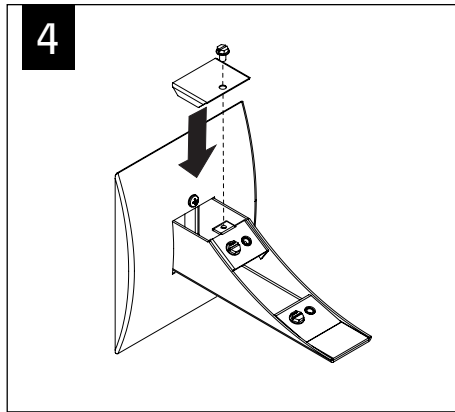
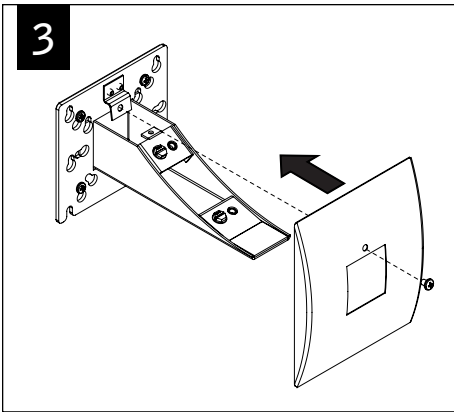

Luminaires must be installed by a qualified electrician (check with local and national codes for proper installation).
To prevent electrical shock, disconnect electrical supply before installation or servicing.

LAMP REMOVAL (DR OPTIC)

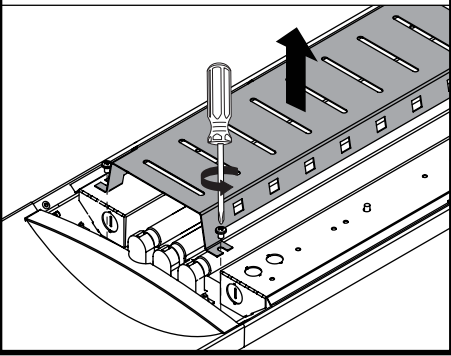

LAMP REMOVAL (PDR OPTIC)

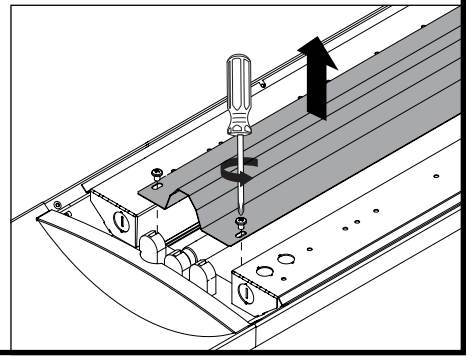
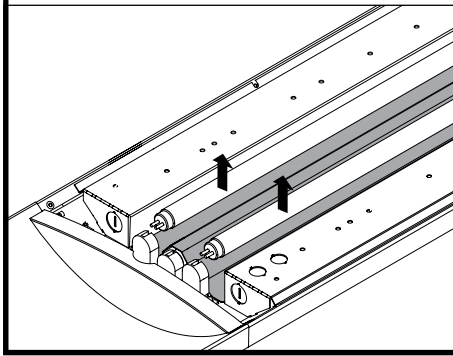

OPTIONAL DUST COVER

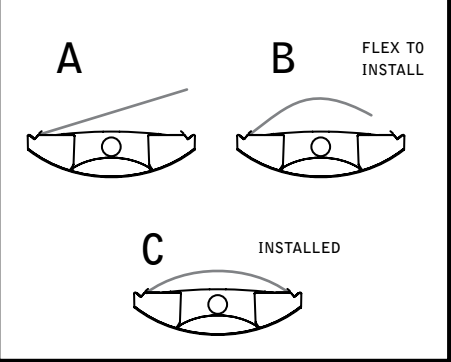

BALLAST SERVICE

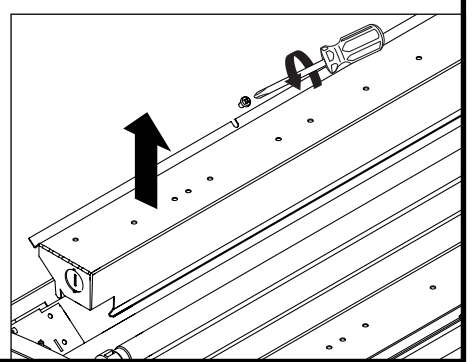
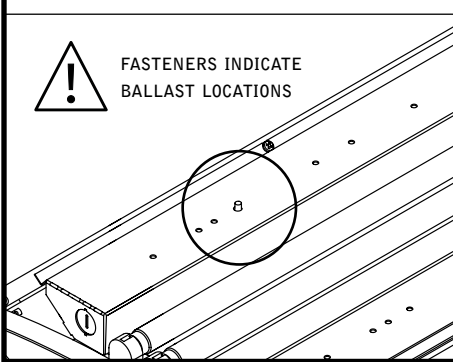

Contractor is responsible for adequately reinforcing walls and/or ceilings to support luminaire weight. Focal Point, LLC accepts no responsibility for inadequately reinforced walls and/or ceilings. The information contained in this drawing is the sole property of Focal Point, LLC. Any reproduction in part or whole without the written permission of Focal Point, LLC is prohibited.