

Seem® 4-LP

FSM4LP



FOCAL POINT®

BEFORE YOU BEGIN

- Luminaires must be installed by a qualified electrician (check with local and national codes for proper installation).
- To prevent electrical shock, disconnect electrical supply before installation or servicing.
- Contractor is responsible for adequately reinforcing walls and/or ceilings to support fixture weight.
- Focal Point, LLC accepts no responsibility for inadequately reinforced walls and/or ceilings.
- The information contained in this drawing is the sole property of Focal Point, LLC. Any reproduction in part or whole without the written permission of Focal Point, LLC is prohibited.

INSTRUCTION KEY

- ATTENTION
- SEE ADDITIONAL INSTRUCTIONS
- POWER OFF
- POWER ON

COMPONENT KEY

FOCAL POINT

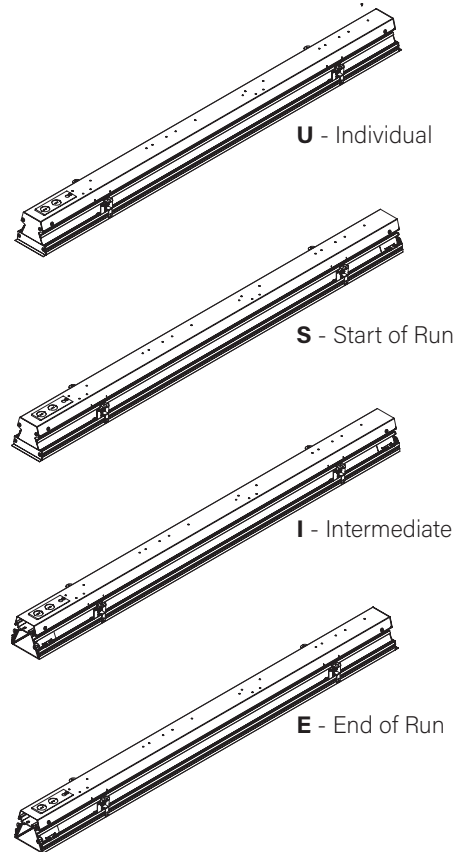

SHIPPED INSTALLED

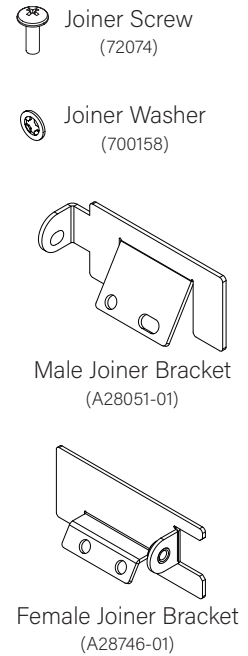

SPACING FOR ALL GRID TYPES

Flush Lens

15/16" Grid

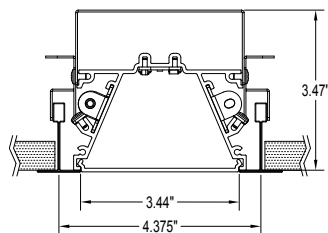

9/16" Grid

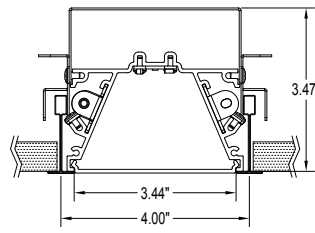

Regress Lens

15/16" Grid

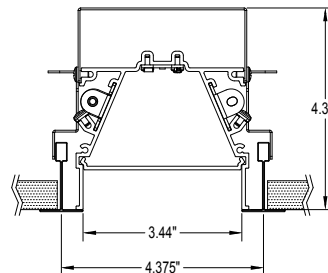

9/16" Grid

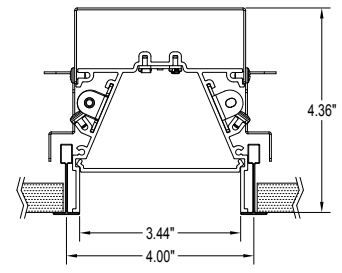

- GRID MOUNT ONLY
- EMERGENCY CONTROL DEVICE (ECD) ADDS 0.125" TO OVERALL HEIGHT

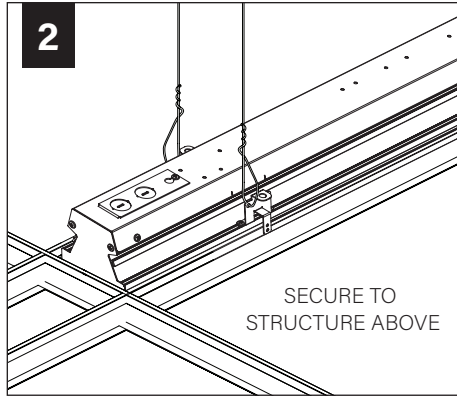
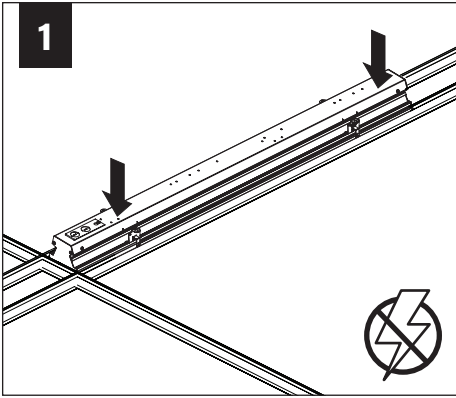

INDIVIDUAL INSTALLATIONS
SKIP TO STEP 6

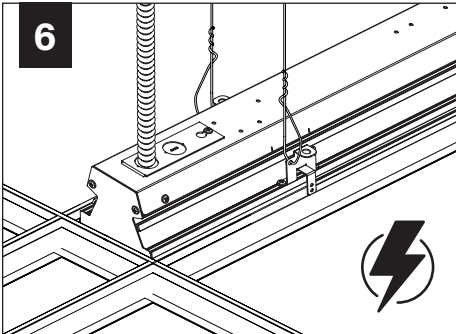
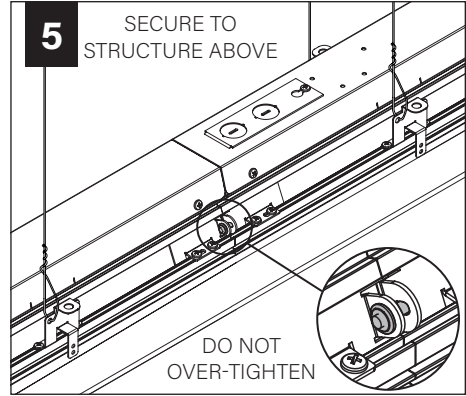
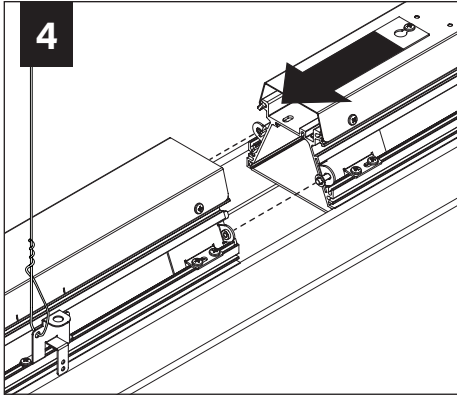
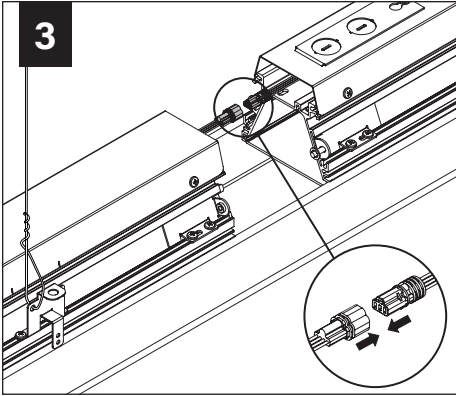

MAKE ELECTRICAL CONNECTIONS

DRIVER SERVICE

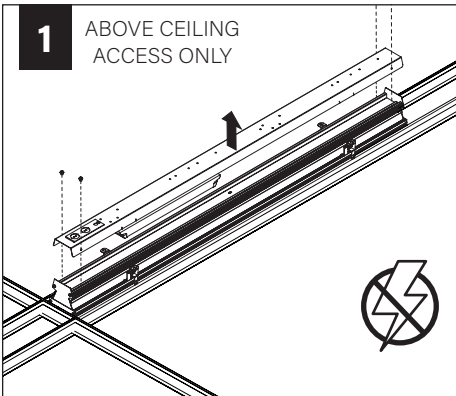

EMERGENCY

I

SEE BATTERY MANUFACTURER INSTRUCTIONS

**EMERGENCY MAXIMUM MOUNTING HEIGHT:
 19.00'**

ACUITY nLIGHT)

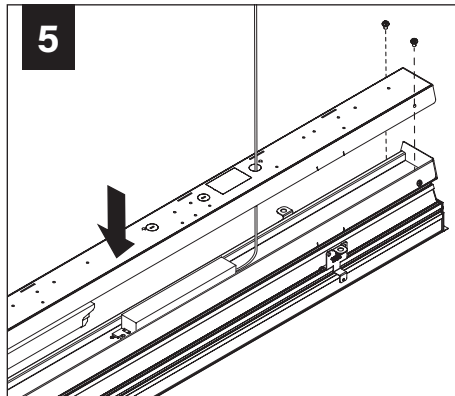
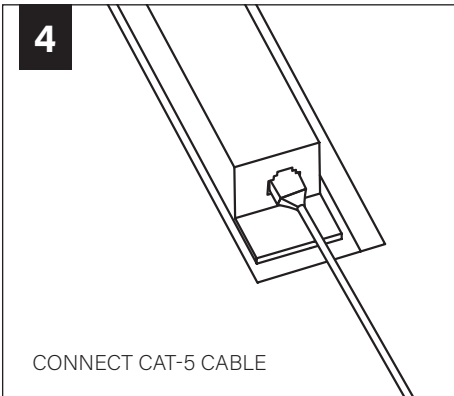
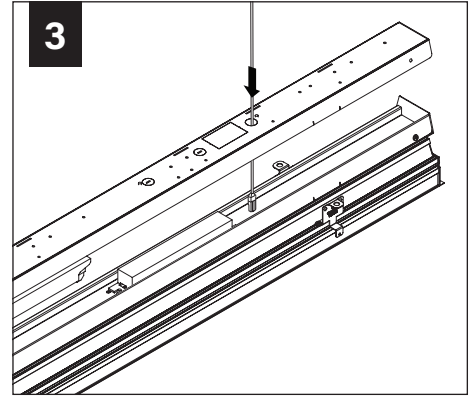
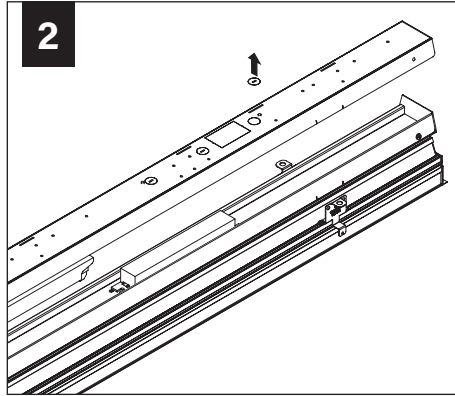
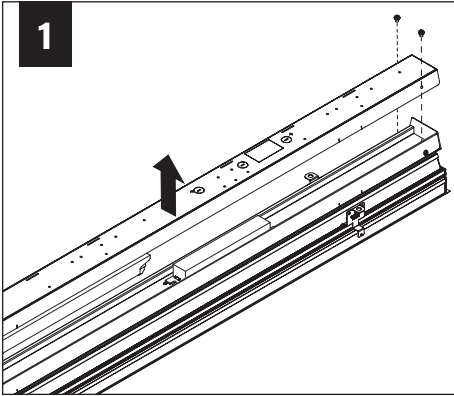

WATTSTOPPER

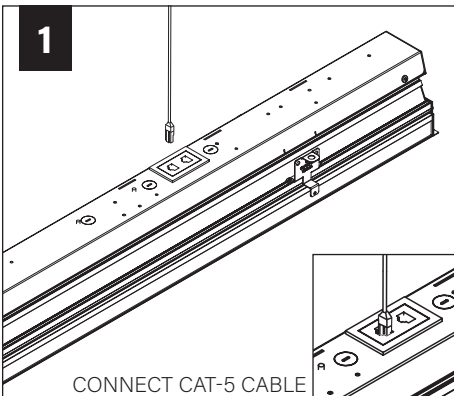

HUBBELL NX

