

seem™ 1 XFN & XFW mounting bracket

CATALOG LOGIC | CATALOG LOGIC



FOCAL POINT®

BEFORE YOU BEGIN

- Luminaires must be installed by a qualified electrician (check with local and national codes for proper installation).
- To prevent electrical shock, disconnect electrical supply before installation or servicing.
- Contractor is responsible for adequately reinforcing walls and/or ceilings to support fixture weight.
- Focal Point, LLC accepts no responsibility for inadequately reinforced walls and/or ceilings.
- The information contained in this drawing is the sole property of Focal Point, LLC. Any reproduction in part or whole without the written permission of Focal Point, LLC is prohibited.

INSTRUCTION KEY

- ATTENTION**
- SEE ADDITIONAL INSTRUCTIONS**
- POWER OFF**
- POWER ON**

COMPONENT KEY

FOCAL POINT

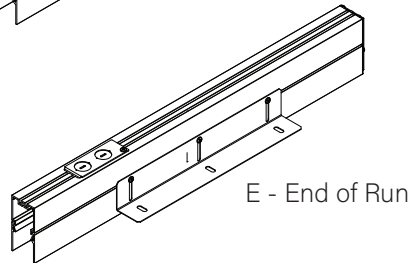
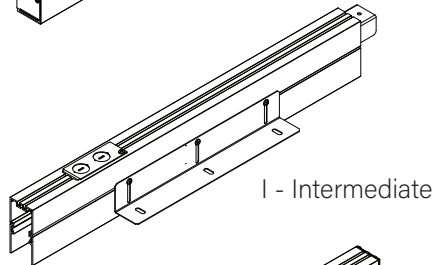
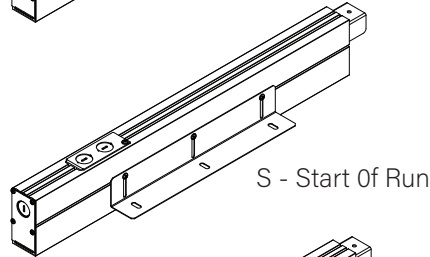
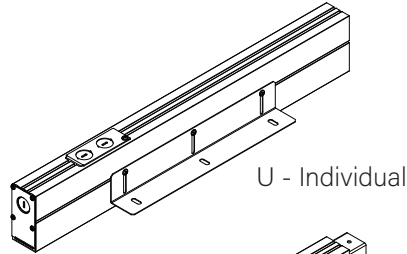

PARTS LIST

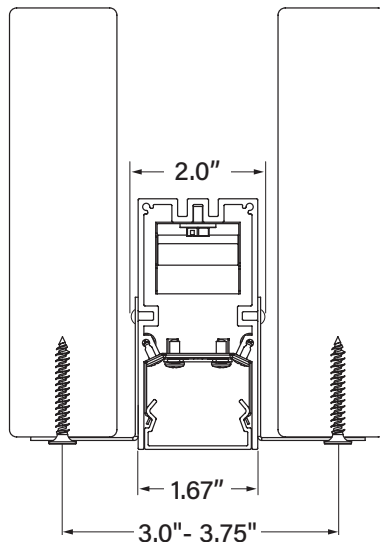
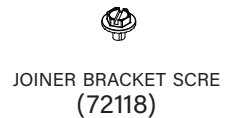
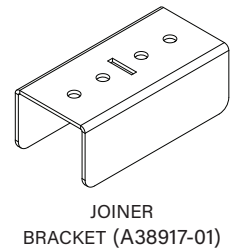
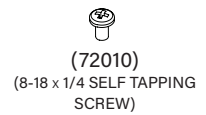
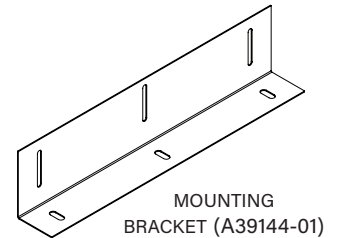

FIXTURE LENGTH	NUMBER OF MOUNTING KITS
1' 11"	1
2'	1
2' 11"	1
3'	2
4'	2
4' 11"	2
5'	3
6'	3
6' 11"	3
7'	4
7' 11"	4
8'	4

MOUNTING BRACKET INSTALLATION

1

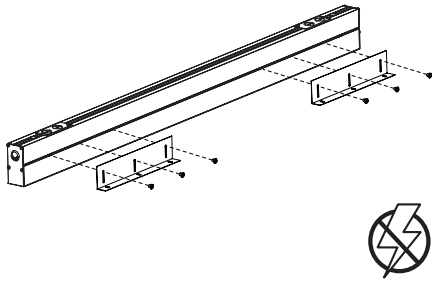

2

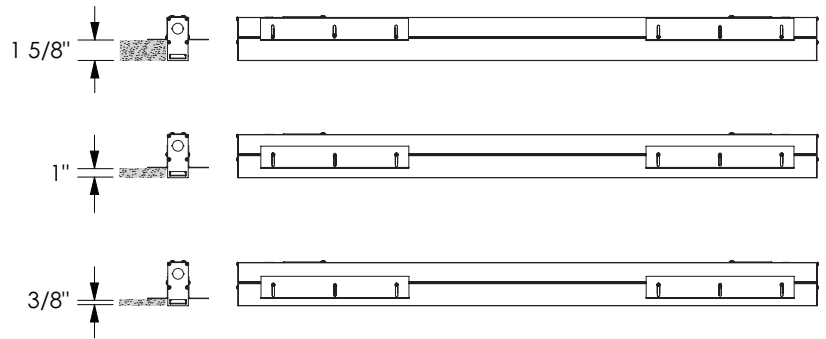

ADJUST MOUNTING BRACKET HEIGHT TO DESIRED MATERIAL THICKNESS FROM 3/8" TO 1 5/8"
CONSULT FACTORY FOR MATERIAL THICKNESS GREATER THAN 1 5/8"

3

SECURE MOUNTING BRACKET TO
INSTALLATION SUPPORTS,
IF APPLICABLE
(HARDWARE BY OTHERS)

JOINING (START OF RUN, INTERMEDIATE, END OF RUN ONLY)

1

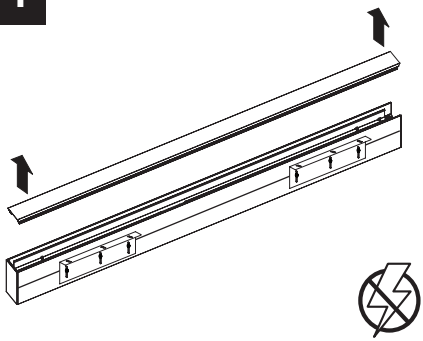

2

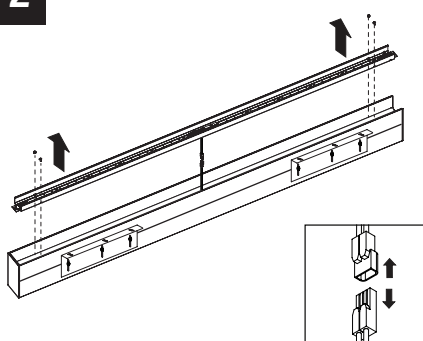

3

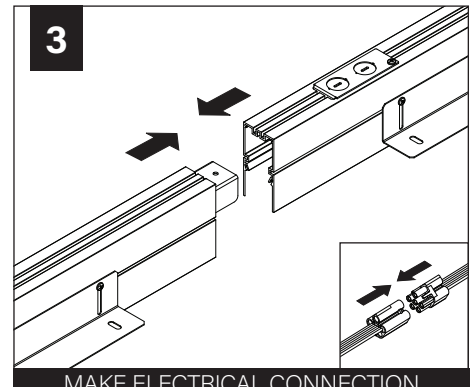

4

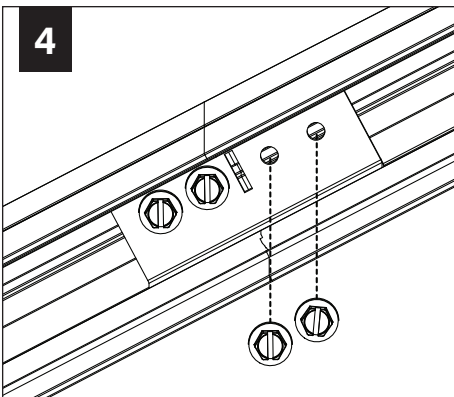

5

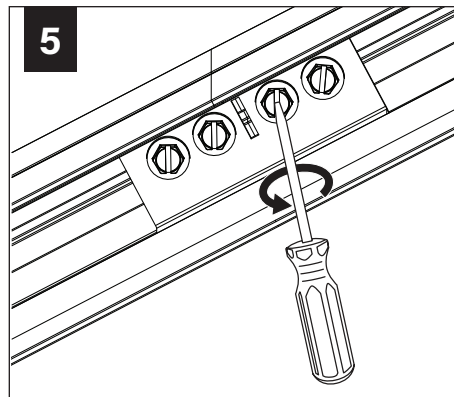

6

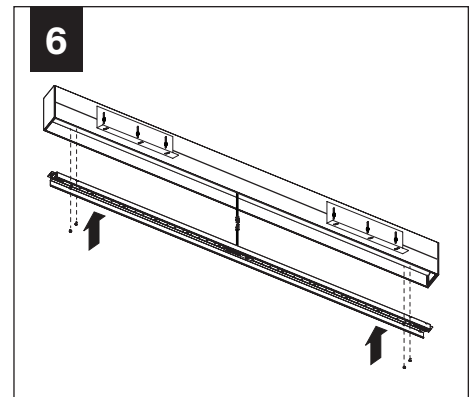

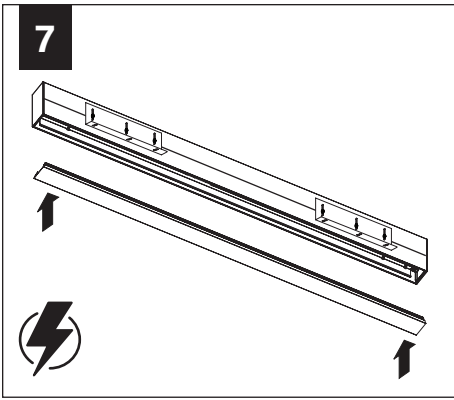

DRIVER SERVICE

