

# Seem™ 1 Indirect

Wall Mount | FSM1IW



FOCAL POINT®

## BEFORE YOU BEGIN

- Luminaires must be installed by a qualified electrician (check with local and national codes for proper installation).
- To prevent electrical shock, disconnect electrical supply before installation or servicing.
- Contractor is responsible for adequately reinforcing walls and/or ceilings to support fixture weight.
- Focal Point, LLC accepts no responsibility for inadequately reinforced walls and/or ceilings.
- The information contained in this drawing is the sole property of Focal Point, LLC. Any reproduction in part or whole without the written permission of Focal Point, LLC is prohibited.

## INSTRUCTION KEY

- ATTENTION
- SEE ADDITIONAL INSTRUCTIONS
- POWER OFF
- POWER ON

## COMPONENT KEY

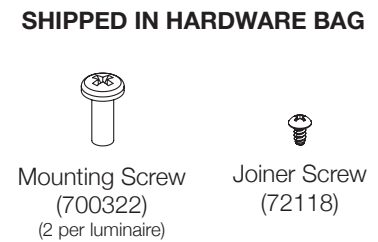
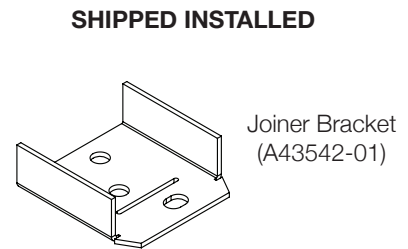
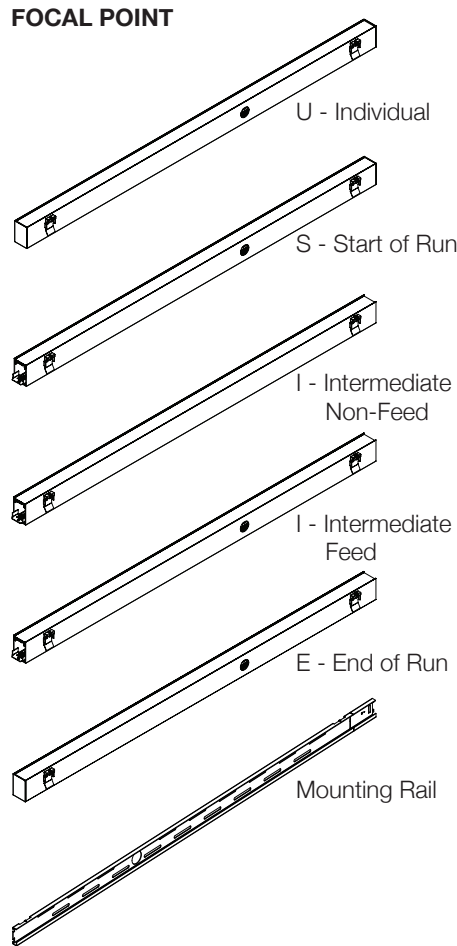

Configurations are run specific, please consult factory drawings before beginning installation.

## INDIVIDUAL UNIT INSTALLATION FOLLOW STEPS 1-6, 11 & 12

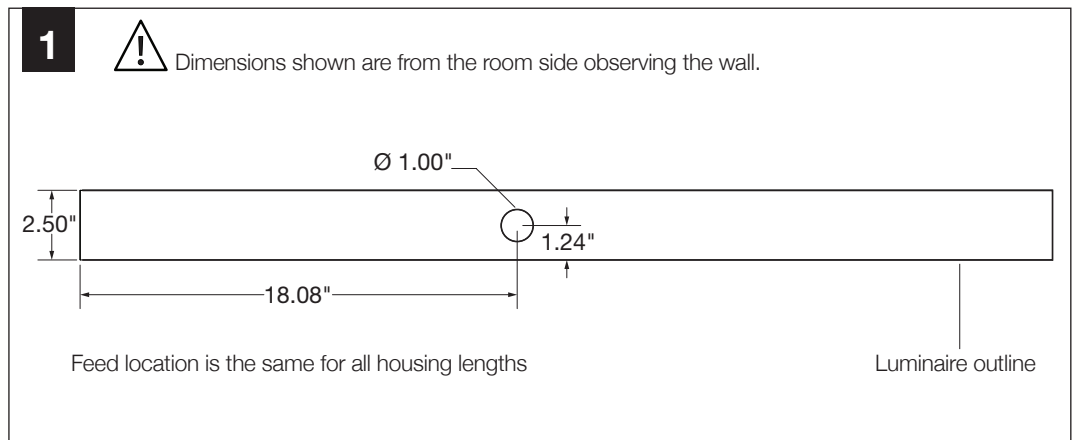
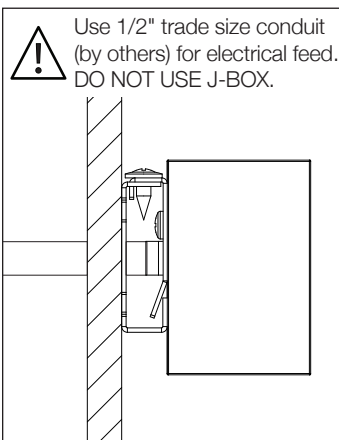

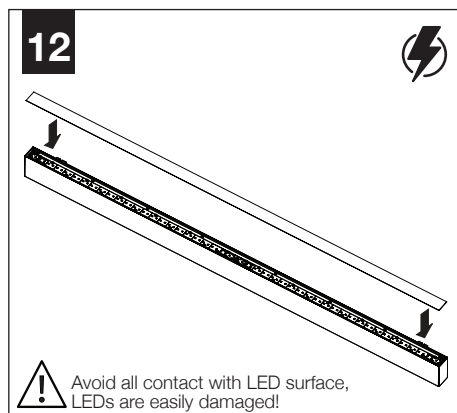
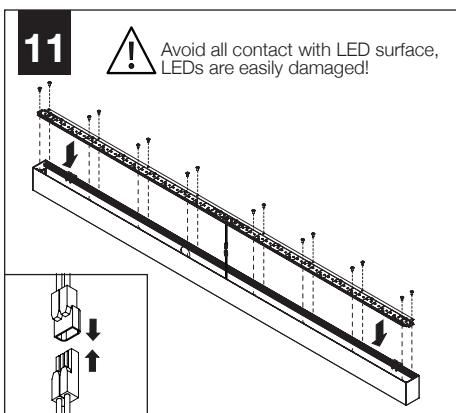
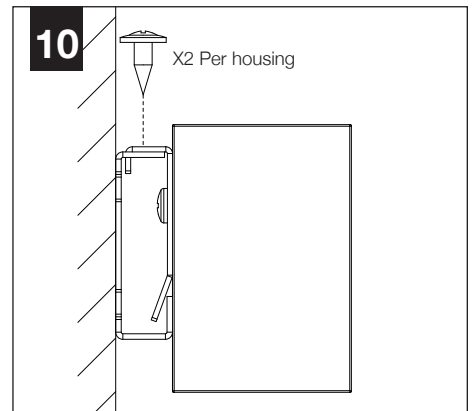
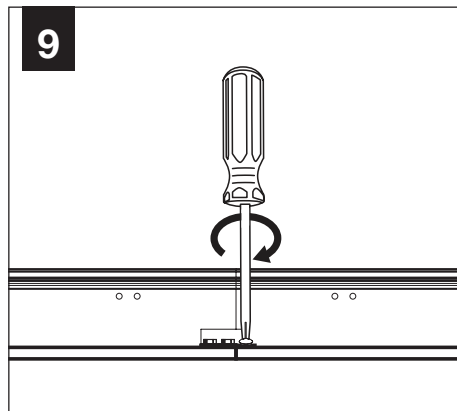
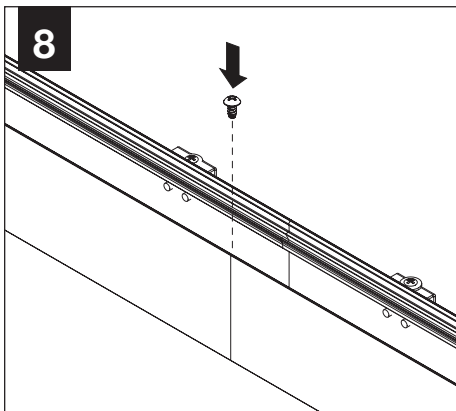
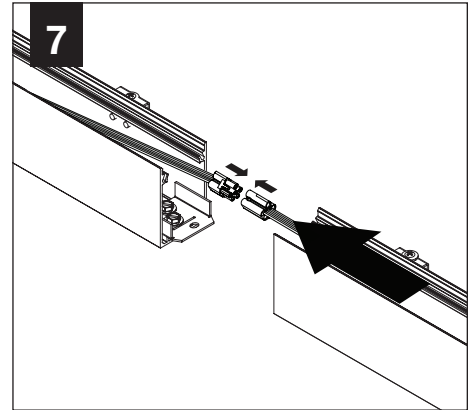
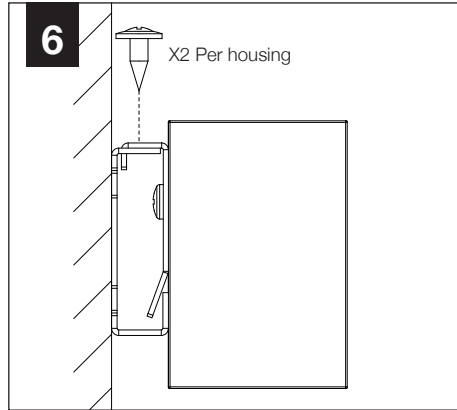
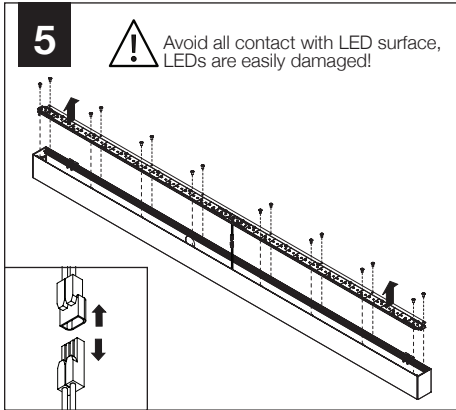
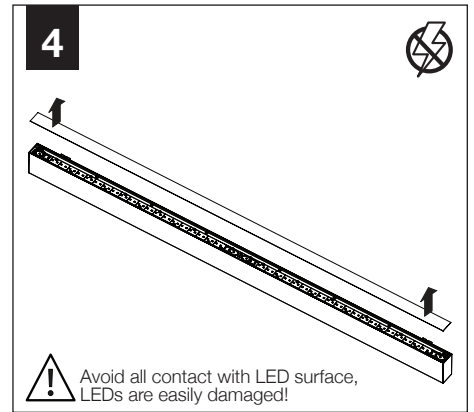
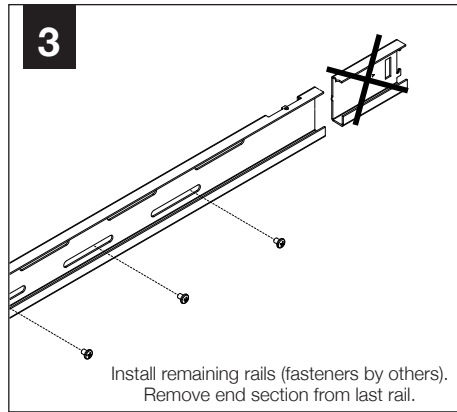
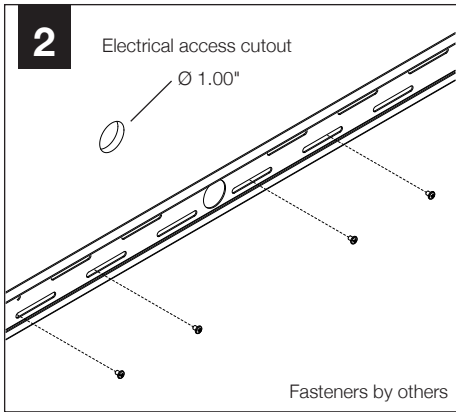

# DRIVER SERVICE

