

equation™

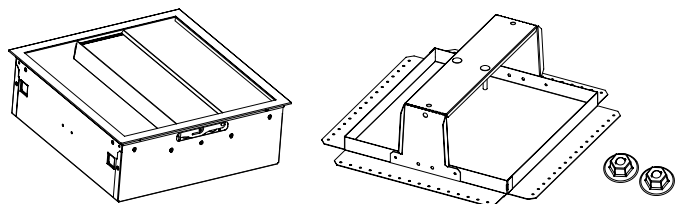

FEQ 1x1



FOCAL POINT



KEY

-  POWER OFF
-  POWER ON
-  ATTENTION

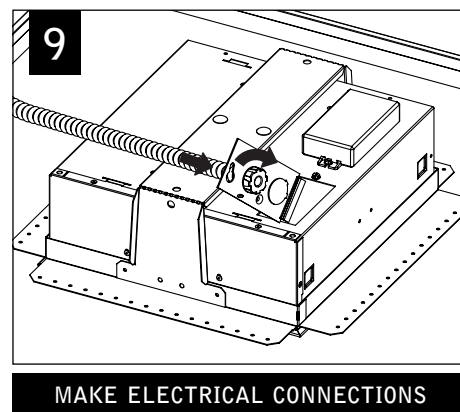
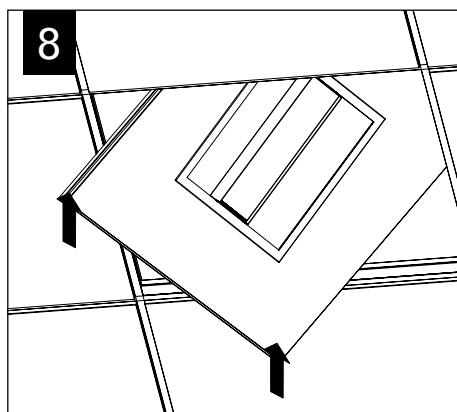
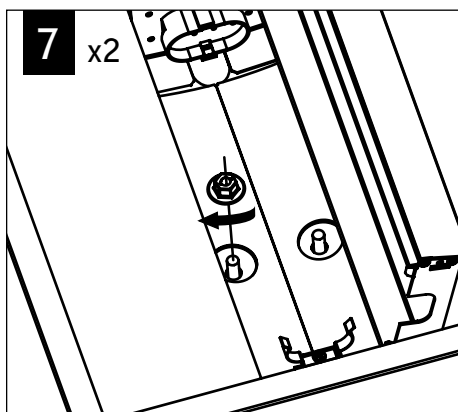
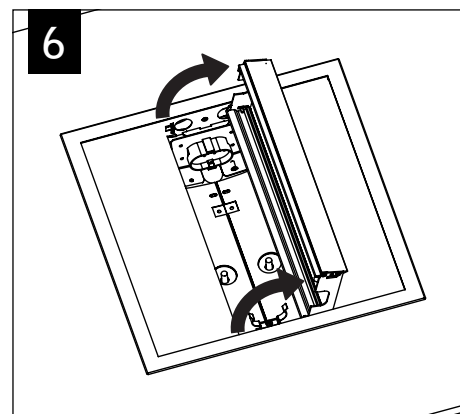
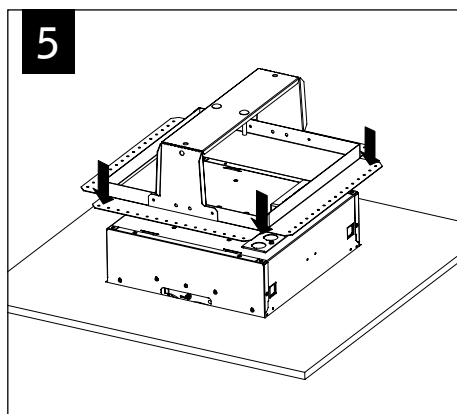
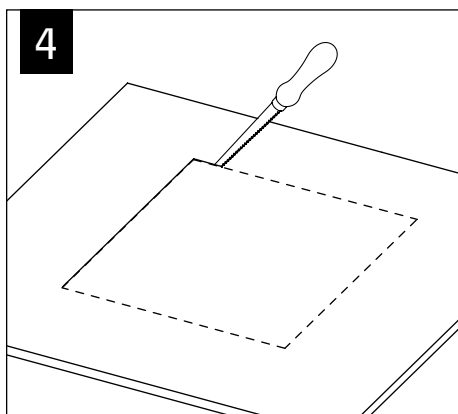
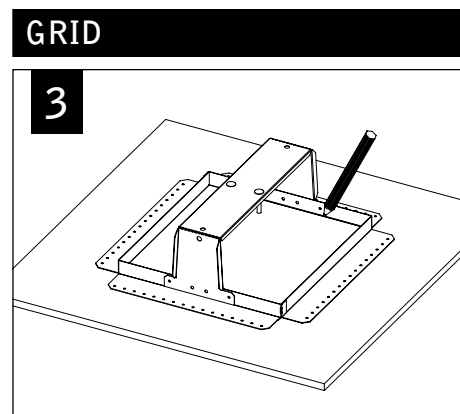
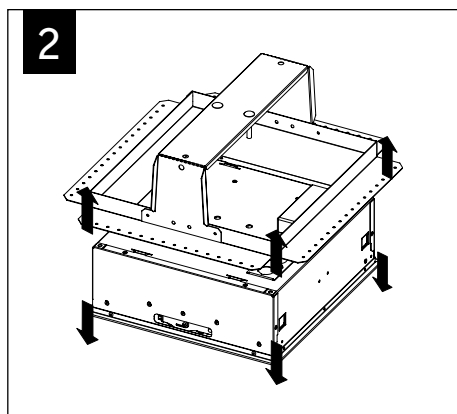
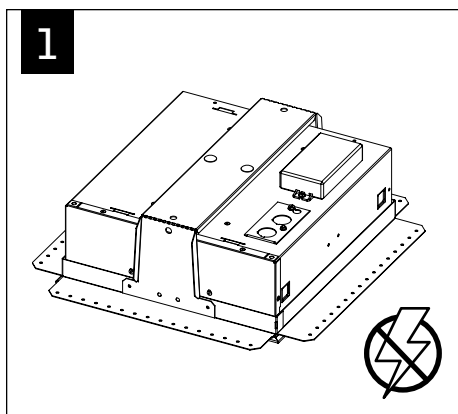

MAKE ELECTRICAL CONNECTIONS

Luminaires must be installed by a qualified electrician (check with local and national codes for proper installation).
To prevent electrical shock, disconnect electrical supply before installation or servicing.

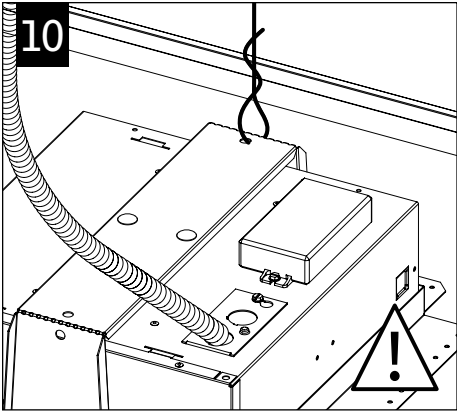

DRYWALL

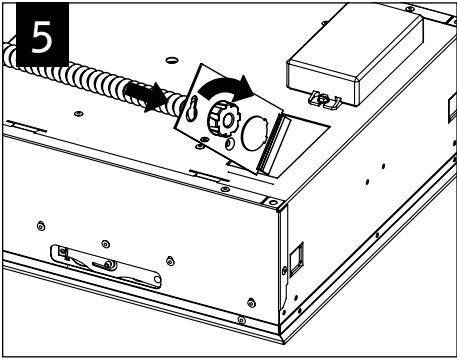
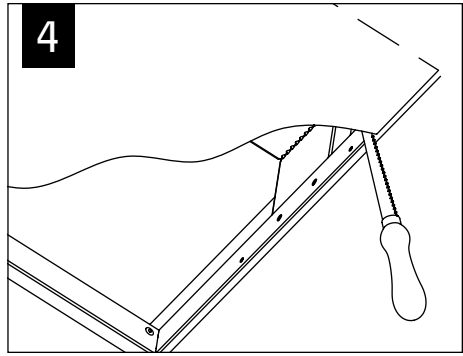
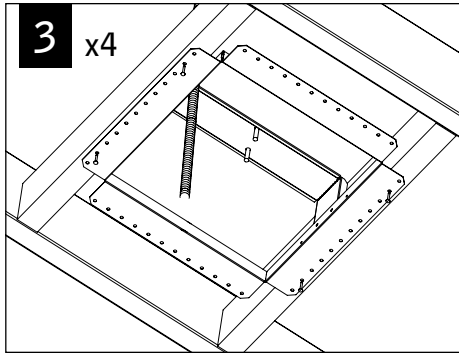

MAKE ELECTRICAL CONNECTIONS

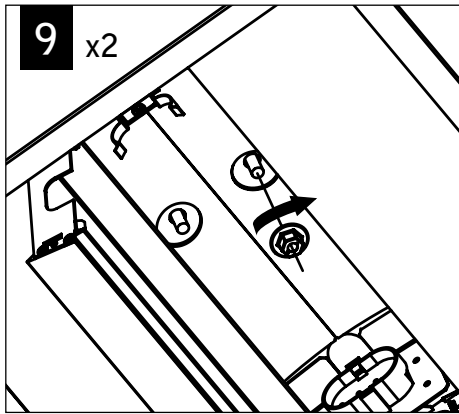
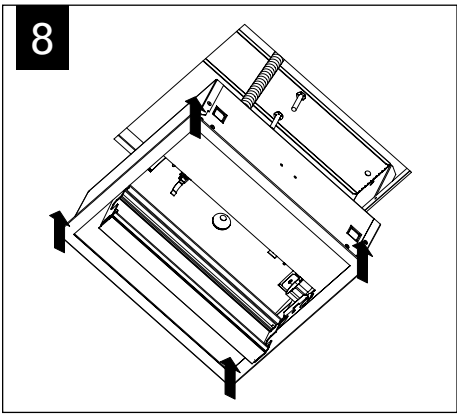
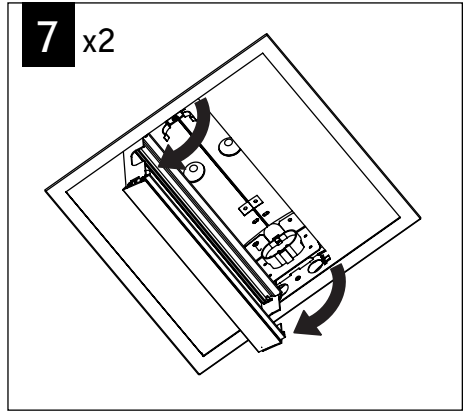
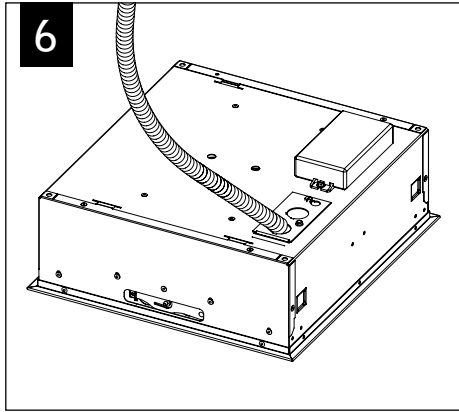

LAMPING

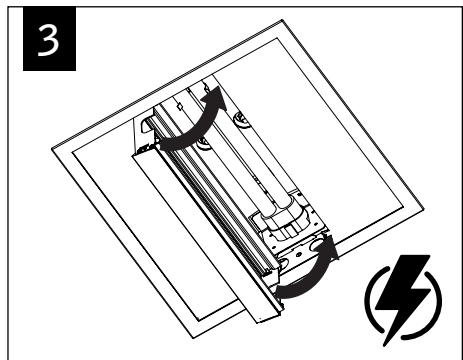
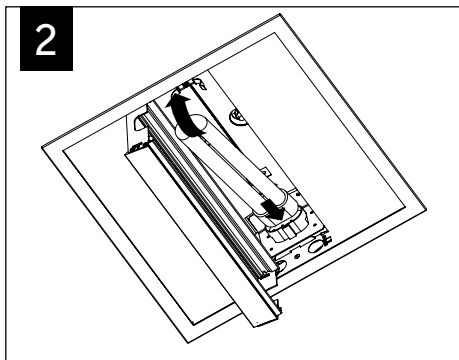
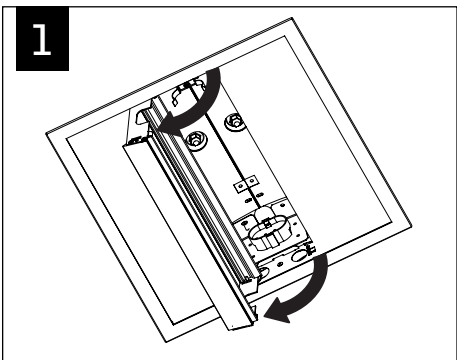

Contractor is responsible for adequately reinforcing walls and/or ceilings to support luminaire weight. Focal Point, LLC accepts no responsibility for inadequately reinforced walls and/or ceilings. The information contained in this drawing is the sole property of Focal Point, LLC. Any reproduction in part or whole without the written permission of Focal Point, LLC is prohibited.