

avenue® B techzone®

FAVBTZ



FOCAL POINT®

FOCAL POINT

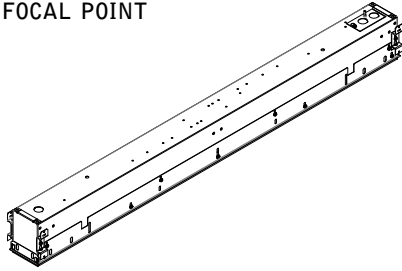

4FT LUMINAIRE WEIGHT: 7LBS

5FT LUMINAIRE WEIGHT: 8LBS

KEY



POWER OFF



POWER ON



ATTENTION

TEE SPACING

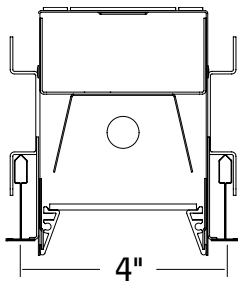

1

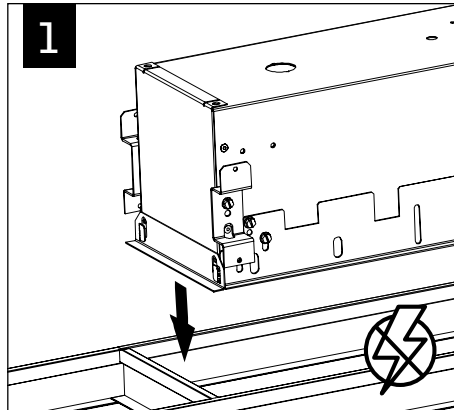

2

IF LUMINAIRE DOES NOT SIT FLUSH, LOOSEN SCREWS TO ADJUST

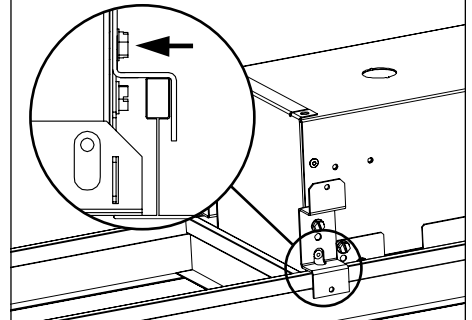

3

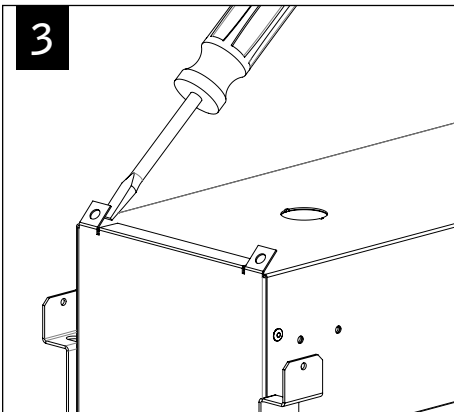

4



SECURE TO STRUCTURE ABOVE

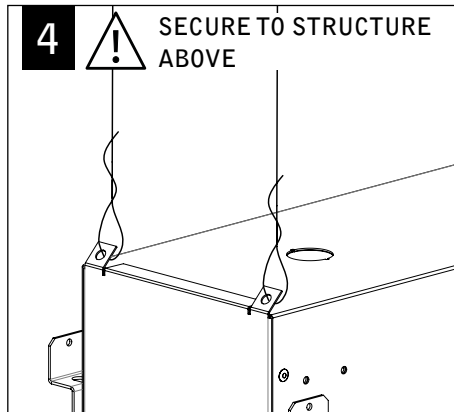

OPTIONAL

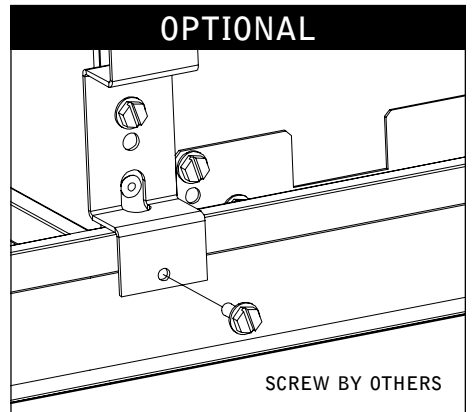

5

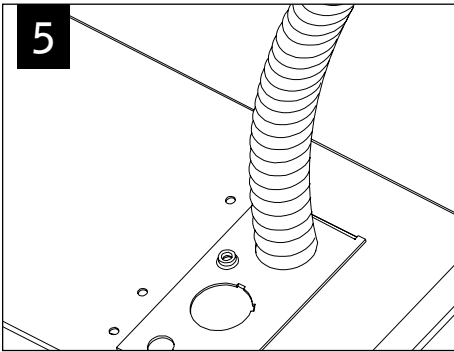

MAKE ELECTRICAL CONNECTIONS

6

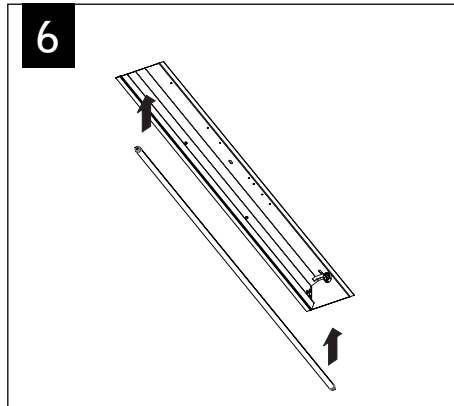

7

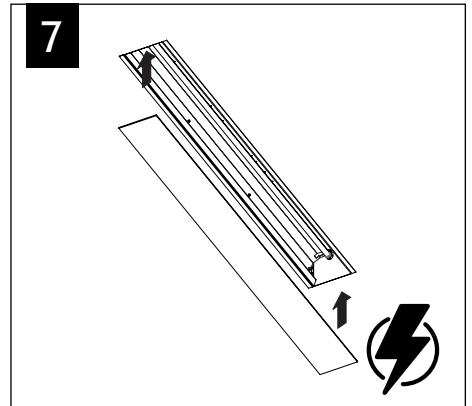

Luminaires must be installed by a qualified electrician (check with local and national codes for proper installation).
To prevent electrical shock, disconnect electrical supply before installation or servicing.

BALLAST SERVICE

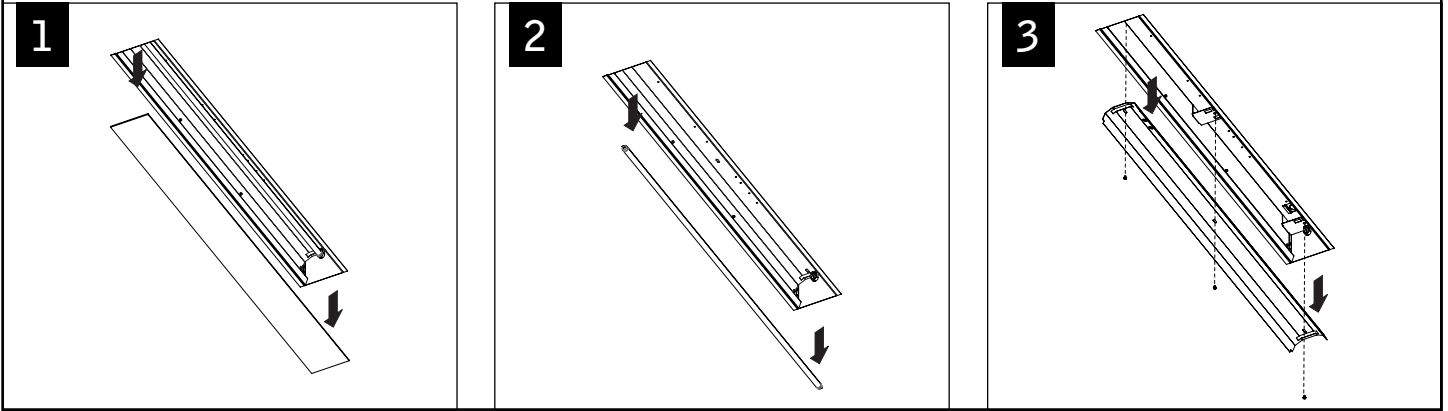

Contractor is responsible for adequately reinforcing walls and/or ceilings to support luminaire weight. Focal Point, LLC accepts no responsibility for inadequately reinforced walls and/or ceilings. The information contained in this drawing is the sole property of Focal Point, LLC. Any reproduction in part or whole without the written permission of Focal Point, LLC is prohibited.