

skydome™ surface mount

FSD-22|33|44-SM



FOCAL POINT®

FOCAL POINT



MOUNTING HARDWARE
PROVIDED BY OTHERS

WEIGHTS: 2' - 37LBS
3' - 53LBS
4' - 78LBS

KEY



POWER OFF



POWER ON



ATTENTION

MOUNTING LOCATIONS

2' DIAMETER

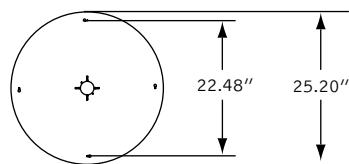

3' DIAMETER

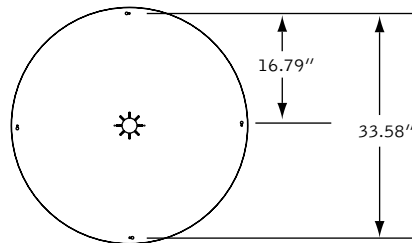

4' DIAMETER

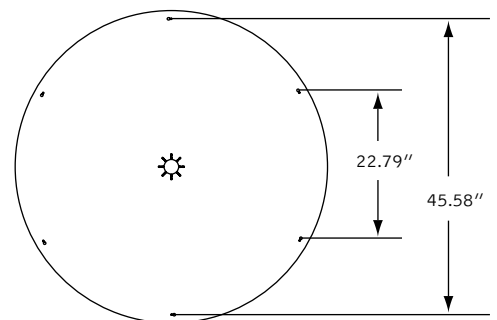

1

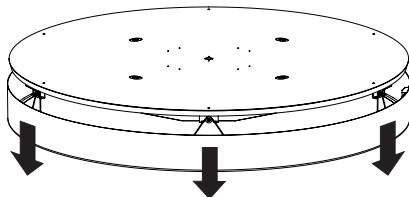

TIGHT FIT, MULTIPLE
PEOPLE REQUIRED.

2

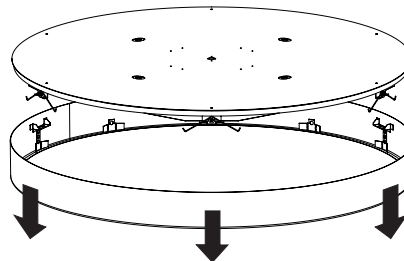

3

2' DIAMETER

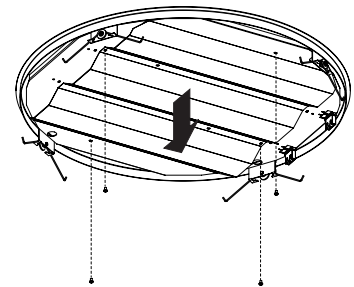

3

3' & 4' DIAMETERS

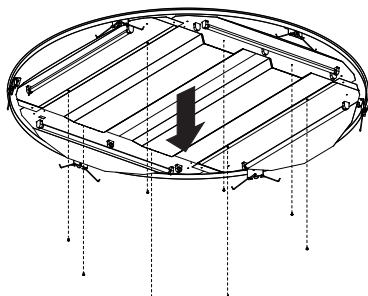

4

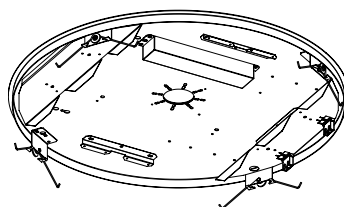

SEE MOUNTING LOCATIONS
ABOVE. HARDWARE
PROVIDED BY OTHERS.

5

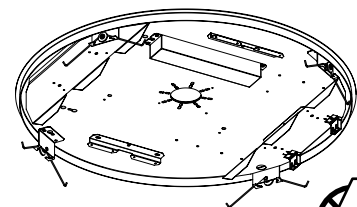

MAKE ELECTRICAL CONNECTIONS

Luminaires must be installed by a qualified electrician (check with local and national codes for proper installation).
To prevent electrical shock, disconnect electrical supply before installation or servicing.

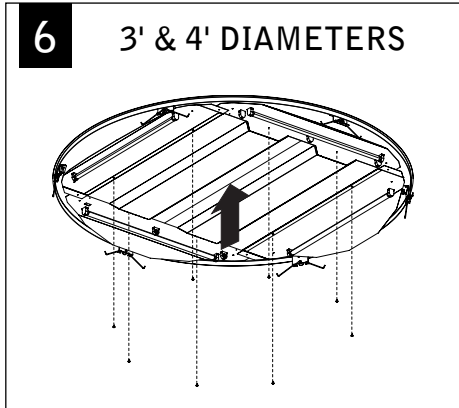
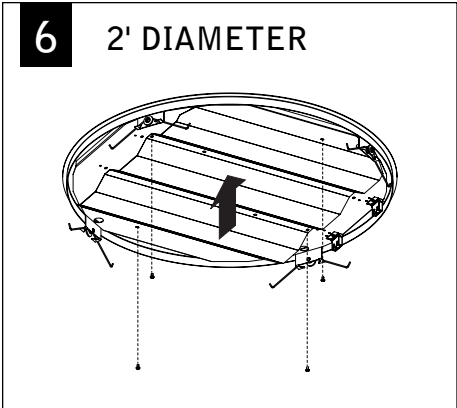

LAMPING CONFIGURATIONS

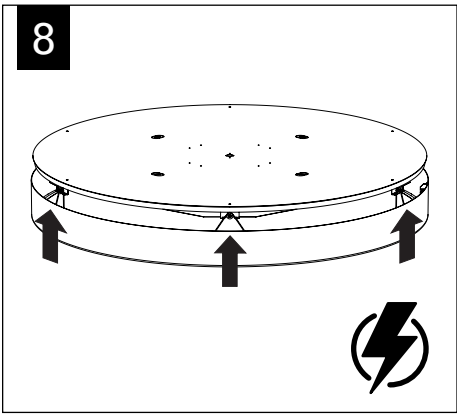
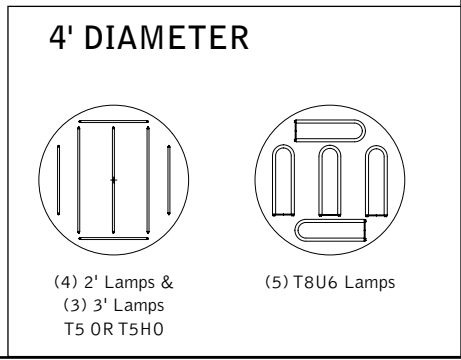
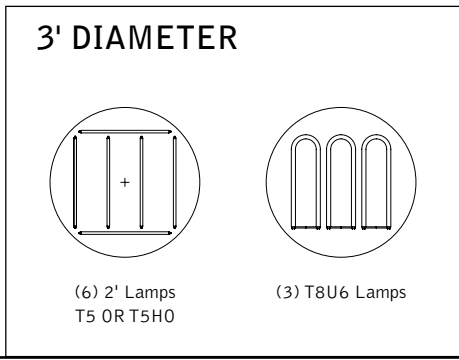
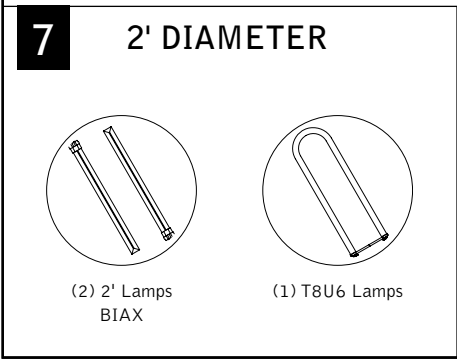

BALLAST SERVICE

FOLLOW
INSTALLATION
STEPS 1-3

Contractor is responsible for adequately reinforcing walls and/or ceilings to support luminaire weight. Focal Point, LLC accepts no responsibility for inadequately reinforced walls and/or ceilings. The information contained in this drawing is the sole property of Focal Point, LLC. Any reproduction in part or whole without the written permission of Focal Point, LLC is prohibited.