

covelight™ 47/58

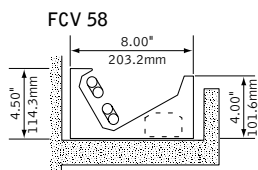

FCV-47|58

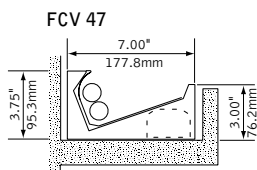
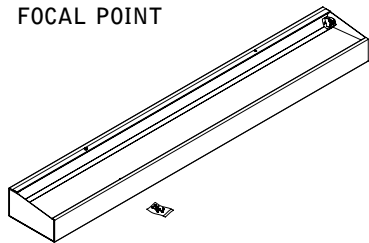

FOCAL POINT



KEY

-  POWER OFF
-  POWER ON
-  ATTENTION

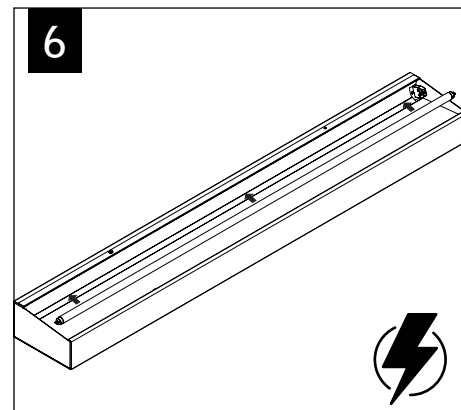
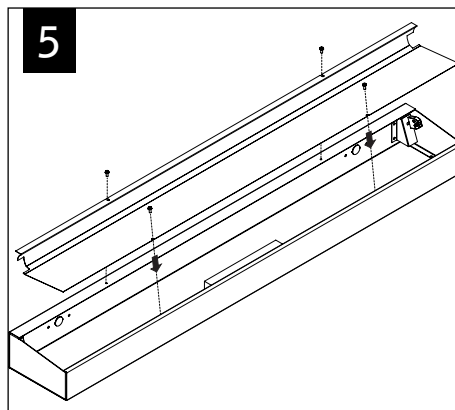
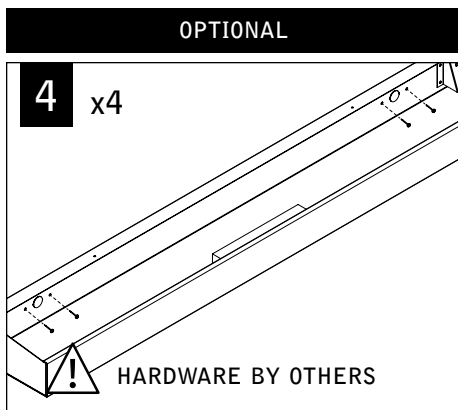
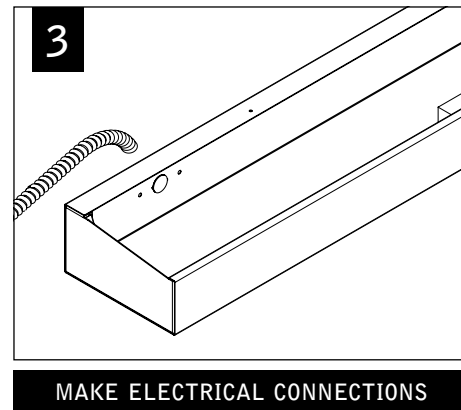
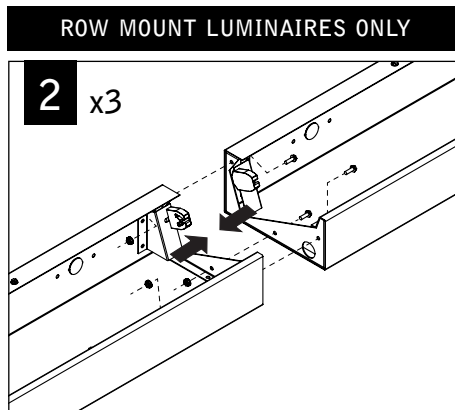
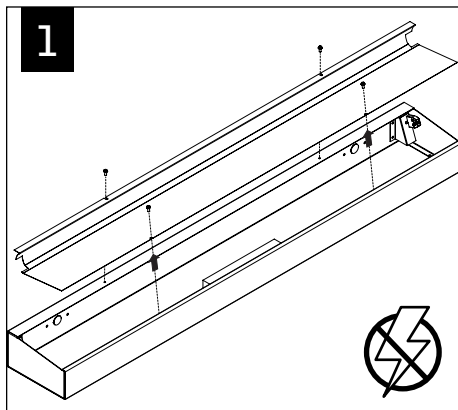

BALLAST SERVICE

REMOVE LAMPS
AND FOLLOW STEP 1
TO REMOVE INNER
REFLECTOR

Luminaires must be installed by a qualified electrician (check with local and national codes for proper installation).
To prevent electrical shock, disconnect electrical supply before installation or servicing.

Contractor is responsible for adequately reinforcing walls and/or ceilings to support luminaire weight. Focal Point, LLC accepts no responsibility for inadequately reinforced walls and/or ceilings. The information contained in this drawing is the sole property of Focal Point, LLC. Any reproduction in part or whole without the written permission of Focal Point, LLC is prohibited.